

Instructions manual for installation of flat solar collectors on the inclined tile roof.

03/2021

Read before installation.



This installation instructions applies collectors:

flat collector	installation orientation	absorber type	absorber material *1	width	height	depth	collector weight	area	connecting system	fluid volume	optimum flow rate, min/max	Stagnation temperature
symbol	-	-	-	A	B	C	m	S	-	V	m	TS
unit	-	-	-	mm	mm	mm	kg	m ²	-	dm ³	dm ³ /h	°C
ES2V/2,65 Al-Cu	vertical	meander	Al-Cu	1120	2356	85	49	2,65	clamp	2,20	75 - 105	192
ES2V/2,65	vertical	meander	Cu-Cu	1120	2356	85	49	2,639	clamp	2,20	75 - 105	201,5
ES2V/2,52 Al-Cu	vertical	meander	Al-Cu	1120	2250	85	48	2,52	clamp	2,10	75-105	210
ES2V/2,52 Al-Al	vertical	meander	Al-Al	1120	2250	85	47	2,52	o-ring v.1.	2,10	75-105	210
ES2V/2,0 HE	vertical	meander	Cu-Cu	1006	2008	85	40	2,02	clamp	1,80	60 - 90	193,7
EM2V/2,0 Al-Cu	vertical	meander	Al-Cu	1006	1988	85	40	2,0	clamp	1,80	60 - 90	190,3
EM1V/2,0 Al-Cu	vertical	double harp	Al-Cu	1006	1988	85	40	2,0	clamp	1,80	60 - 90	202,3
ES2V/2,0 AL	vertical	meander	Al-Al	1006	2007	85	39	2,19	o-ring v.1.	1,70	60 - 90	185
ES2H/2,65 Al-Cu	horizontal	meander	Al-Cu	2356	1120	85	49	2,65	o-ring v.1.	2,20	75 - 105	192

*1 Cu-Cu – highly selective sheet=Cu, hydraulic system=Cu;
Al-Al – highly selective sheet=Al, hydraulic system=Al;
Al-Cu – highly selective sheet=Al, hydraulic system=Cu.

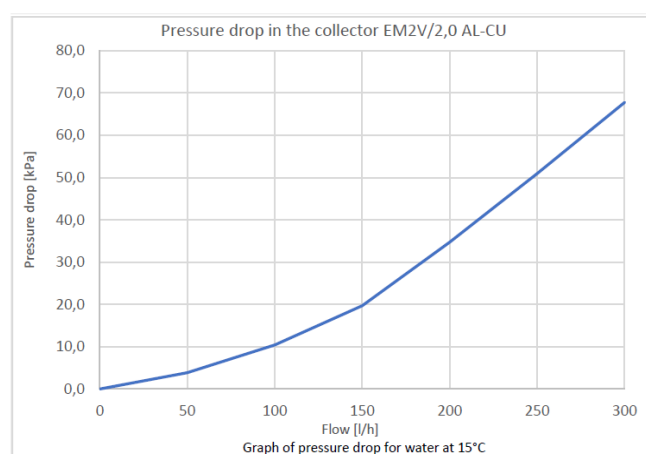
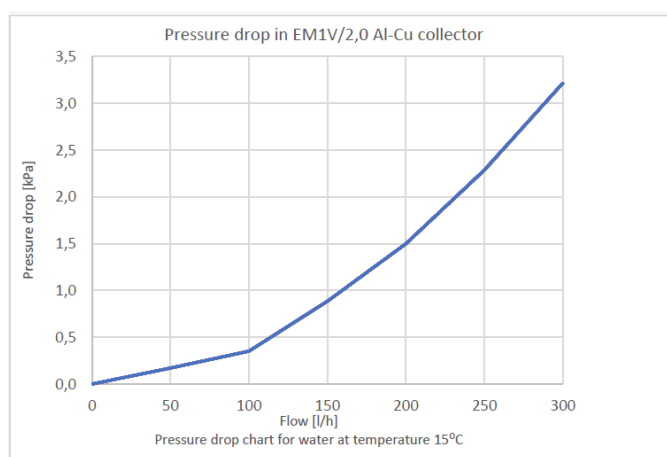

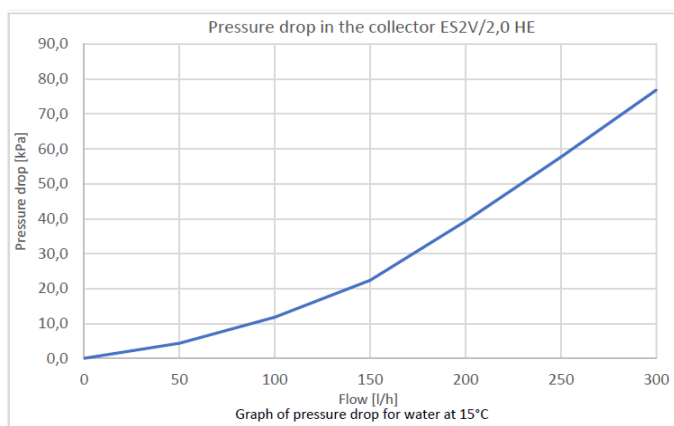
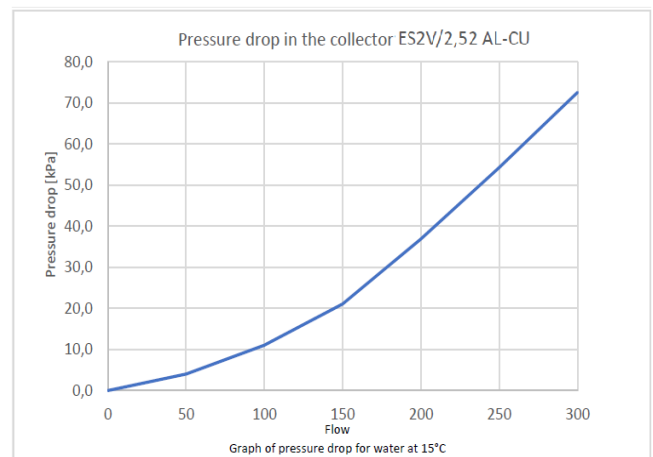
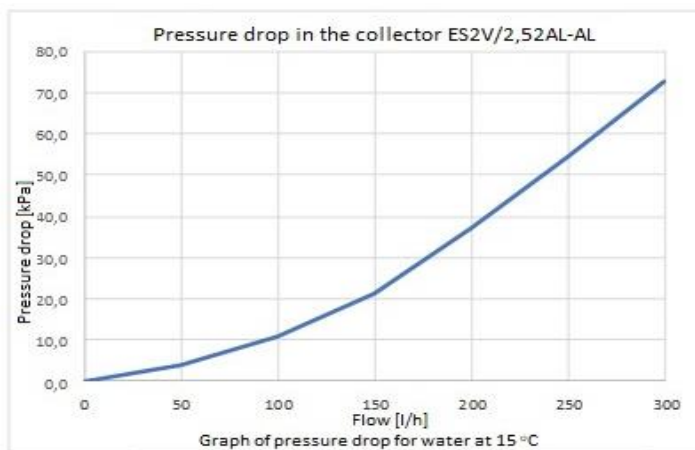
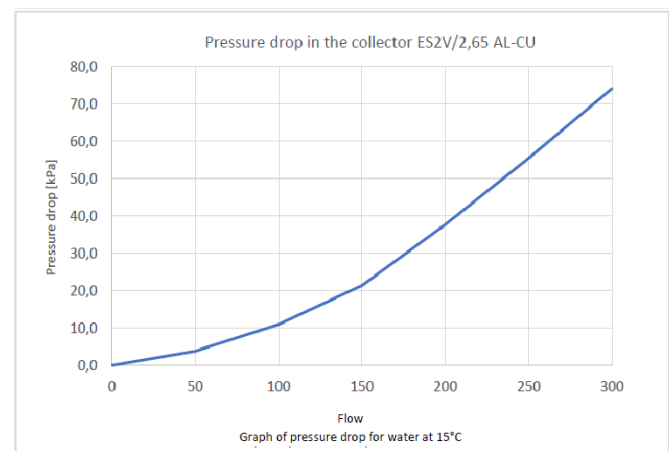
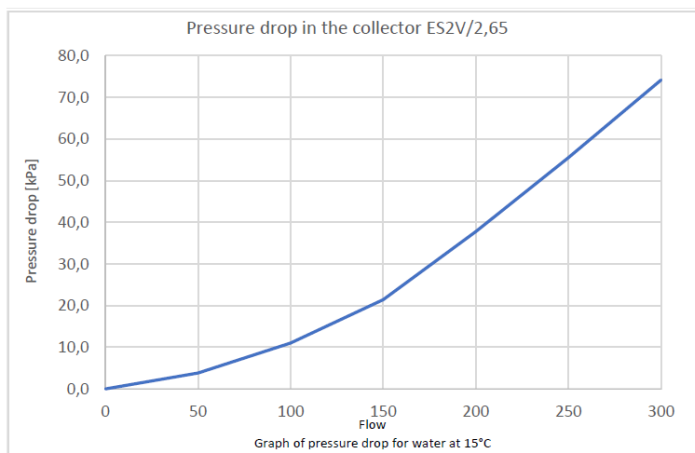
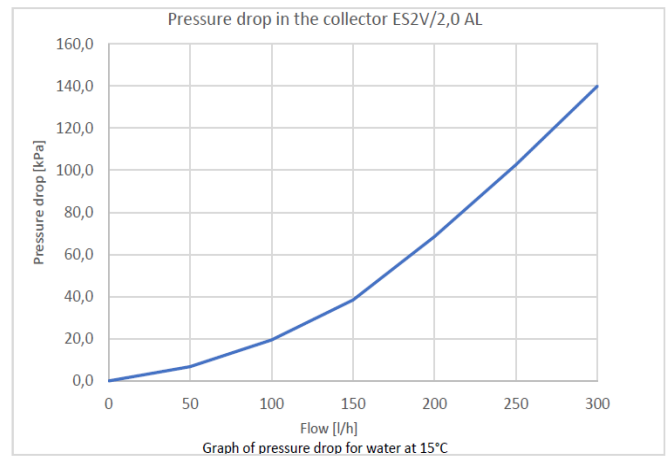
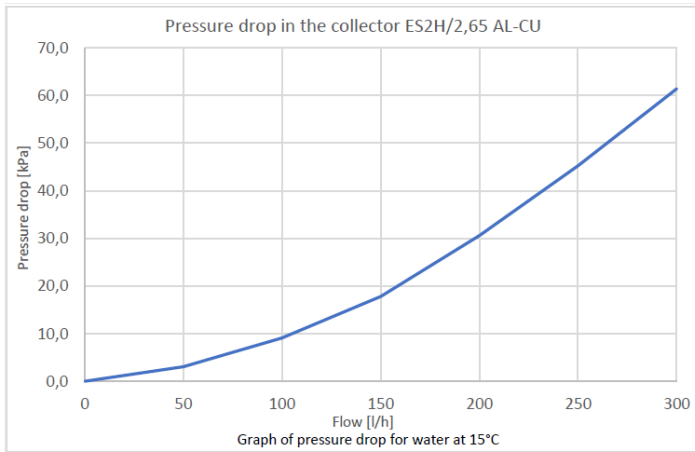

1. General information

Lightning protection system



The lightning protection system must be carried out in accordance with the applicable regulations.

Recycling



Completely worn out solar collectors may be returned to the manufacturer. The returned solar collectors will be recycled by the manufacturer with as little effect on the environment as possible.

2. Safety during installation

Read the safety guidelines immediately prior to the installation!

2.1 Notes included in the instructions manual

This installation instructions manual includes important information on safety and proper positioning of the collectors on the roof as well as the instructions for correct construction of the hydraulic connection.

The drawings and information in this instructions manual apply to both the vertical and horizontal installation of the collectors.

The installation of the collectors described in the manual can only be performed by qualified persons with professional experience in water supply and gas systems.

After completion of works, the installer should hand over the installation instructions manual to the customer and clearly explain the principles of operation and provide guidelines for proper operation of the solar system.

2.2 Intended use

This instructions manual includes a description of the mounting set used for installation of the collectors on the roof with the inclination ranging from 30° up to 65°. This set is intended exclusively for the installation of solar collectors and it must not be used to mount any other devices on the roof. The installation of only solar collectors on the supporting structure ensures safety of operation.

3. Before installation



Tip.

The installation works on the roof can be dangerous, therefore it is recommended to hire a roofing company.

DANGER OF GETTING SCALDED

In the event when the solar collectors and assembly materials are exposed to solar radiation for a long time, there is a risk of getting scalded by hot components.



To avoid the danger of getting scalded, you should:

- wear protective clothing,
- cover the collector and the assembly materials with a canvass cover (so as to reduce heating them by the sunshine).



Caution

When the collectors are packed vertically on a transport pallet, the following unloading instructions should be followed.

Read the instructions below before you start unloading the vertical pallet of collectors!

- 1) The first step before unloading is to place the transport pallet on a flat surface. Figure 1.1 shows the transport pallet placed on a flat hardened ground.
- 2) The second step of unloading is to put a 30 mm-high board under the transport pallet with collectors so that the inclined pallet is stable. Figure 2.1 describes the conditions to be met by the transport pallet before unloading.
- 3) Once the conditions for positioning of the transport pallet have been met, you may start unloading the collectors. Use extreme caution when unloading (**COLLECTORS ARE PROTECTED AT THE FRONT OF THE PALLET ONLY**). Photo 3.1 shows the transport pallet ready for unloading.
- 4) When a collector is taken out, you must **absolutely secure** the next one until it is unloaded.

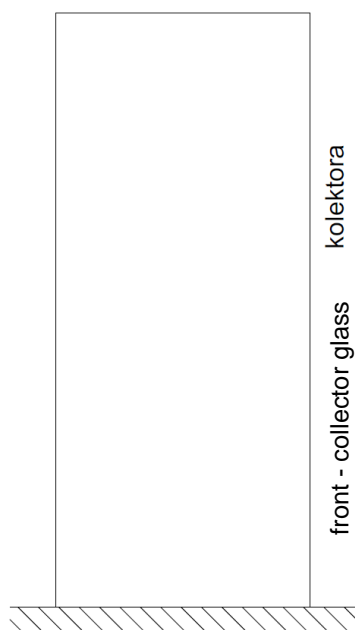

1.1 Transport position

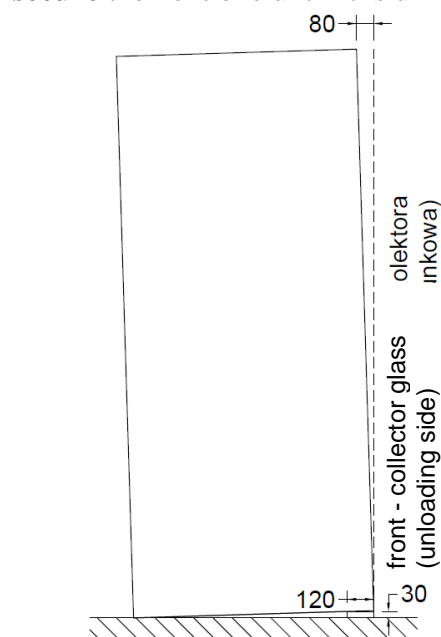

2.1 Unloading position



3.1 Transport pallet ready for unloading

3.1 Completeness of delivery



Before the installation check that the delivery is complete (according to the drawing below) and the delivered components are free of damage.

- in case of any damage, the defective component or part should be immediately replaced,
- the replacement needs to be carried out using the original spare parts only.

Roofing holder

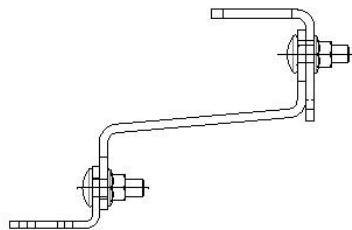

Set of clamping bolt 1

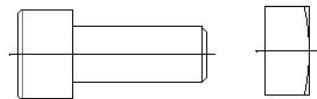

Set of clamping bolt 2

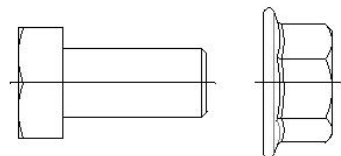

Fastening plate
Side Inter-Collector

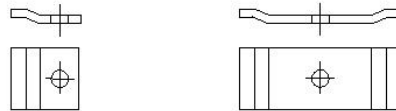

Fastening holder

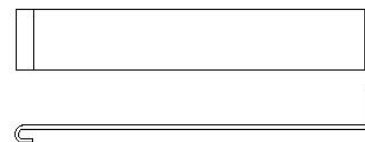

Multi-slot section connector



Multi-slot section



3.1.2 Completeness of delivery of the mounting set – inclined roof, roofing tiles, using the pipe union

Mounting set			Battery									
No.	Name	unit	1	2	3	4	5	6	7	8	9	10
1.	Roofing holder	pcs.	4	6	8	10	12	14	16	18	20	22
	Wood screw	pcs.	20	30	40	50	60	70	80	90	100	110
2.	Side fastening plate PMB35	pcs.	4	4	4	4	4	4	4	4	4	4
3.	Inter-collector fastening plate PMM112	pcs.	0	2	4	6	8	10	12	14	16	18
4.	2.0m ² collectors, vertical Multi-slot section l=2240	pcs.	2*1120	2*2240	2*1120 + 2*2240	4*2240	2*1120 + 4*2240	6*2240	2*1120 + 6*2240	8*2240	2*1120 + 8*2240	10*2240
5.	2.52m ² and 2.65m ² collectors, vertical Multi-slot section l=2460	pcs.	2*1230	2*2460	2*1230 + 2*2460	4*2460	2*1230 + 4*2460	6*2460	2*1230 + 6*2460	8*2460	2*1230 + 8*2460	10*2460
6.	2.65m ² collectors, horizontal Multi-slot section l=2500	pcs.	2x2500	4x2500	6x2500	8x2500	10x2500	-	-	-	-	-
7.	Fastening holder UM114	pcs.	2	4	6	8	10	12	14	16	18	20
8.	Set of clamping bolt 1	set	4	6	12	16	20	24	28	32	36	40
	- allen screw INOX M8x20											
	- INOX M8 square nut											
9.	Set of clamping bolt 2	set	4	6	12	14	20	22	28	30	36	38
	- INOX M10x20 screw											
	- nut with a collar INOX M10											
10.	Self-drilling screw	pcs.	2	4	6	8	10	12	14	16	18	20

3.1.3 Completeness of delivery of the mounting set – inclined roof, roofing tile/foundation using the threaded union

Mounting set			Battery				
No.	Name	unit	1	2	3	4	5
1.	Roofing holder	pcs.	4	6	8	10	12
	Wood screw	pcs.	20	30	40	50	60
2.	Side fastening plate PMB35	pcs.	4	4	4	4	4
3.	Inter-collector fastening plate PMM112	pcs.	0	0	0	2	2
4.	Inter-collector fastening plate PMM79	pcs.	0	2	4	4	6
5.	2.0m ² collectors, vertical Multi-slot section l=2240	pcs.	2*1120	2*2240	2*1120 + 2*2240	4*2240	2*1120 + 4*2240
6.	2.52m ² and 2.65m ² collectors, vertical Multi-slot section l=2460	pcs.	2*1230	2*2460	2*1230 + 2*2460	4*2460	2*1230 + 4*2460
.	2.65m ² collectors, horizontal Multi-slot section l=2500	pcs.	2x2500	4x2500	6x2500	8x2500	10x2500
8.	Fastening holder UM114	pcs.	2	4	6	8	10
9.	Set of clamping bolt 1	set	4	8	12	16	20
	- allen screw INOX M8x20						
	- INOX M8 square nut						
10.	Set of clamping bolt 2	set	4	6	12	14	20
	- INOX M10x20 screw						
	- nut with a collar INOX M10						
11.	Self-drilling screw	pcs.	2	4	6	8	10

3.1.4 Completeness of delivery of the correction set (optimum version) for the mounting set – inclined tile roof.

The correction set allows the inclination angle of the mounting set to be adjusted between $+15^\circ$ and $+30^\circ$ in relation to the roof inclination. Similarly to the base case of the set, all its components are made of stainless steel and aluminium.



Before the installation check that the delivery is complete (according to the drawing below) and the delivered components are free of damage.

- in case of any damage, the defective component or part should be immediately replaced,
- the replacement needs to be carried out using the original spare parts only.

1. Correction set adapter 1

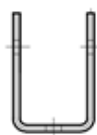

2. Adapter 2 (bent to an appropriate angle)

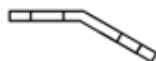

9. Adapter 3



3. Channel section, 40x40

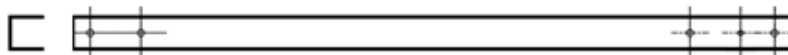

4. Angle brace section, 35x35



5. Horizontal angle section, 35x35



6. Set of adapter bolt 1



7. Set of bolt 2



8. Wide washer (additional, to be screwed with the basic mounting set)



10. Set of bolt 3



3.1.5 Completeness of delivery of the correction set for the mounting set – inclined tile roof.

No.	Correction set Name	No of collectors				
		x1	x2	x3	x4	x5
1	Adapter 1 for correction sets	2	3	4	5	6
2	Adapter 2 (bent to an appropriate angle)	2	3	4	5	6
3	Channel section, 40x40	2	3	4	5	6
4	Angle brace section, 35x35	1	2	3	4	5
5	Horizontal angle section, 35x35	1	2	3	4	5
6	Set of adapter bolt 1	2	3	4	5	6
7	Set of bolt 2	8	13	18	23	28
8	Wide washer (additional, to be screwed with the basic mounting set)	2	3	4	5	6
9	Adapter 3	2	3	4	5	6
10	Set of bolt 3	2	3	4	5	6

3.1.6 Completeness of delivery of the clamp-type connecting system on the compensator for double-harp collector

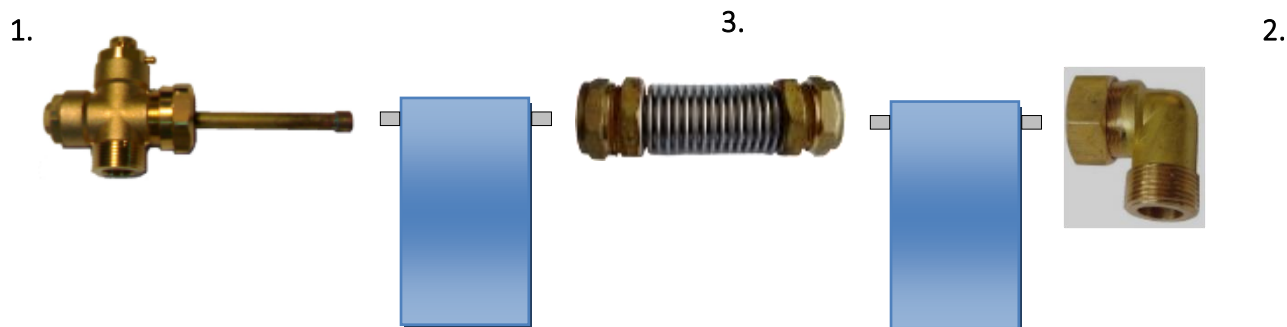

Connecting system for double-harp collectors		unit	Battery				
No.	Name		1	2	3	4	5
1.	Cross fitting Ø22 x GZ3/4" with a vent	pcs.	1	1	1	1	1
2.	Clamping elbow Ø22 x GZ3/4"	pcs.	1	1	1	1	1
3.	Compensator Ø22 x Ø22	pcs.	0	1	2	3	4

3.1.7 Completeness of delivery of the clamp-type connecting system using the threaded union for double-harp collector

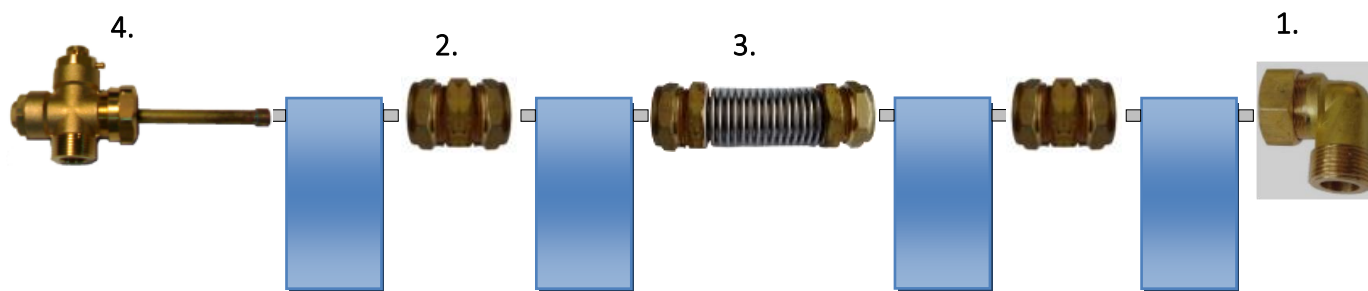

Connecting system for double-harp collectors		unit	Battery				
No.	Name		1	2	3	4	5
1.	Elbow Ø22 x GZ3/4"	pcs.	1	1	1	1	1
2.	Threaded union Ø22 x Ø22	pcs.	0	1	2	2	3
3.	Compensator Ø22 x Ø22*	pcs.	0	0	0	1	1
4.	Cross fitting Ø22 x GZ3/4" with a vent	pcs.	1	1	1	1	1

*The compensator must be installed in case of batteries with 4 and 5 collectors and placed between the 2nd and the 3rd collector.

3.1.8 Completeness of delivery of the clamp-type connecting system on the compensator for meander collector – vertical installation

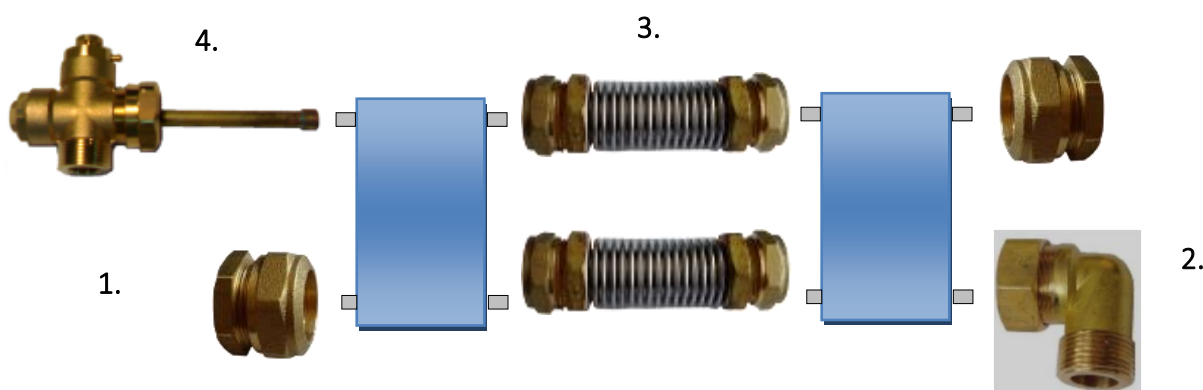

Connecting system for meander collectors		unit	Battery									
No.	Name		1	2	3	4	5	6	7	8	9	10
1.	Clamping plug Ø22	pcs.	2	2	2	2	2	2	2	2	2	2
2.	Clamping elbow Ø22 x GZ3/4"	pcs.	1	1	1	1	1	1	1	1	1	1
3.	Compensator Ø22 x Ø22	pcs.	0	2	4	6	8	10	12	14	16	18
4.	Cross fitting Ø22 x GZ3/4" with a vent	pcs.	1	1	1	1	1	1	1	1	1	1

3.1.9 Completeness of delivery of the clamp-type connection system using the threaded union for meander collector – vertical installation

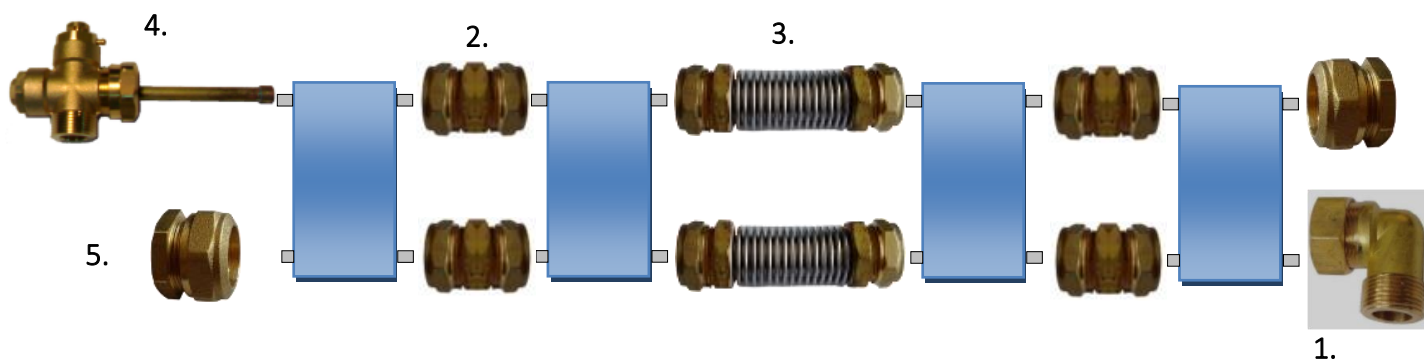

Connecting system for meander collectors			Battery x				
No.	Name	unit	1	2	3	4	5
1.	Elbow Ø22 x GZ3/4"	pcs.	1	1	1	1	1
2.	Threaded union Ø22 x Ø22	pcs.	0	2	4	4	6
3.	Compensator Ø22 x Ø22	pcs.	0	0	0	2	2
4.	Cross fitting Ø22 x GZ3/4" with a vent	pcs.	1	1	1	1	1
5.	Clamping plug Ø22	pcs.	2	2	2	2	2

*The pipe union must be installed in case of batteries with 4 and 5 collectors and placed between the 2nd and the 3rd collector.

3.1.10 Completeness of delivery of the O-ring v.1-type connecting system on the compensator for meander collector – horizontal installation

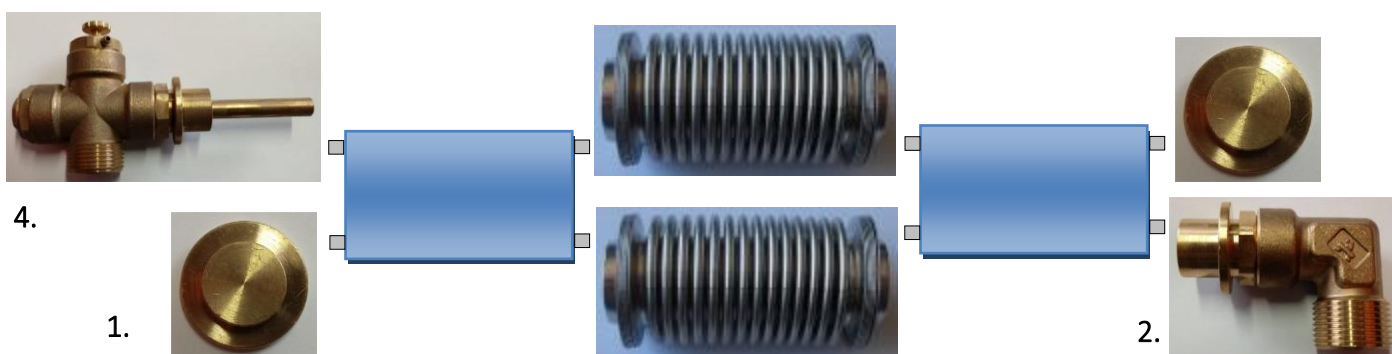

Connecting system for meander collectors			Battery x				
No.	Name	unit	1	2	3	4	5
1.	Plug, O-ring v.1	pcs.	2	2	2	2	2
2.	Elbow x GZ3/4", O-ring v.1	pcs.	1	1	1	1	1
3.	Compensator, O-ring v.1	pcs.	0	2	4	6	8
4.	Cross fitting with a vent, O-ring v.1	pcs.	1	1	1	1	1
5.	Gasket, O-ring v.1	pcs	4	8	12	16	20
6.	Clip, O-ring v.1	pcs	4	8	12	16	20

3.1.1 Completeness of delivery of the O-ring v.1-type connecting system on the compensator for Al-Al meander collector – vertical installation

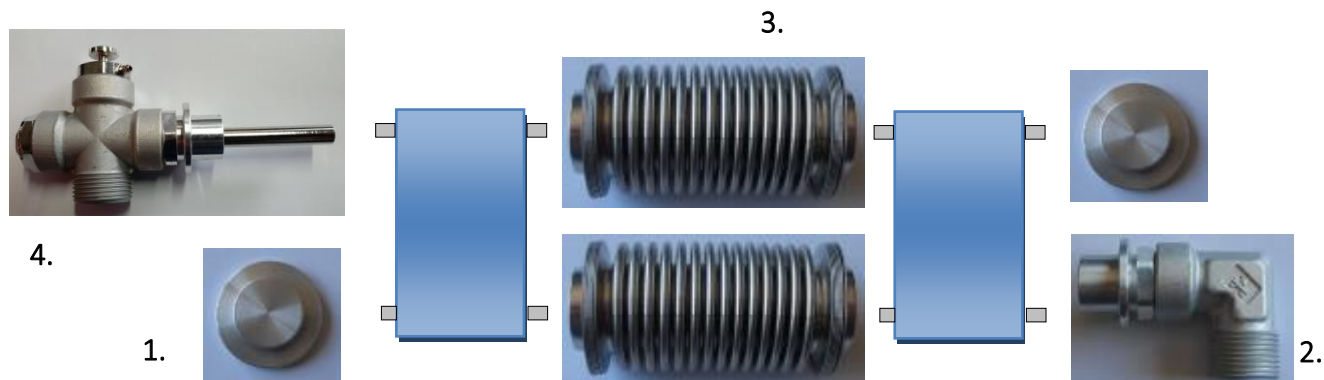

No.	Connecting system for meander collectors Name	unit	Battery x				
			1	2	3	4	5
1.	Plug, O-ring v.1	pcs.	2	2	2	2	2
2.	Elbow x GZ3/4", O-ring v.1	pcs.	1	1	1	1	1
3.	Compensator, O-ring v.1	pcs.	0	2	4	6	8
4.	Cross fitting with a vent, O-ring v.1	pcs.	1	1	1	1	1
5.	Gasket, O-ring v.1	pcs	4	8	12	16	20
6.	Clip, O-ring v.1	pcs	4	8	12	16	20

3.1.12 Completeness of delivery of the O-ring v.1-type connecting system on the compensator for hybrid collector – vertical installation

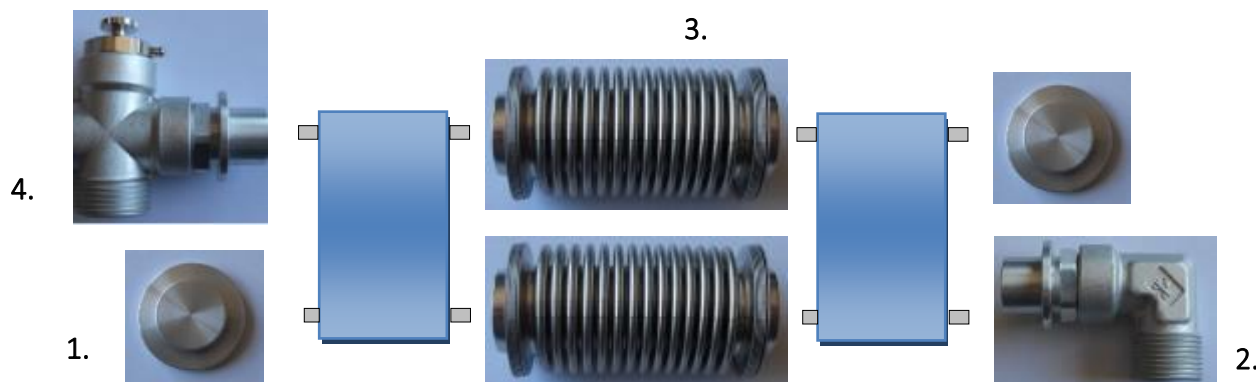

No.	Connecting system Name	unit	Battery x				
			1	2	3	4	5
1.	Plug, O-ring v.1	pcs.	2	2	2	2	2
2.	Elbow x GZ3/4", O-ring v.1	pcs.	1	1	1	1	1
3.	Compensator, O-ring v.1	pcs.	0	2	4	6	8
4.	Cross fitting with a vent, O-ring v.1	pcs.	1	1	1	1	1
5.	Gasket, O-ring v.1	pcs	4	8	12	16	20
6.	Clip	pcs	4	8	12	16	20

3.2 Transport and storage



- during transport the connector pipes of the collectors are protected by rubber caps,
- the collectors should be stored in a dry place. When the collectors are stored outdoors, they should be protected against weather conditions.

3.3 Technical documentation



The solar system consists of different components. Before installation of any of the components read the relevant instructions manual. A specific installation instructions manual is attached to a given device or a piece equipment:

- installation instructions for solar collectors,
- installation instructions for the pump group,
- installation instructions for the solar controller,
- installation instructions for the hot water container.

3.4 Additional tools and equipment

- level,
- harness with protective rope (to work at height),
- scaffolding, roof ladder or crane.

3.5 Location of collector

The potential quantity of the absorbed radiation depends on a proper location of the absorber in relation to the falling sunbeams. The optimum position is to set the collector surface perpendicularly to the falling solar radiation.

Recommended location of collector:

inclination angle:

40 – 45° for full-year systems

approx. 30° for systems used in summer

approx. 60° for systems used in winter

- orientation of a collector the southern direction (or approximate to the southern direction).

The recommended optimum angle of inclination of the collector is between 30° and 75 °.

It is recommended that the collectors should be installed on the southern roof slope. During the installation work, particular attention should be paid to the protection of collectors from being overturned by strong winds.

The maximum permissible snow and wind load is 2.0 kN/m².

The collector field should be located in such a way that the absorber is not shadowed by the adjacent buildings, trees, etc.

In case of a larger number of collector fields, it is important that the front row of collectors does not shadow the next one.

3.6 Required space

The 2.02m² type for vertical installation.

Approx. 2200 mm height and 1200 mm width is required the first collector + 1110 mm width for each consecutive one. In case of mounting collectors on the inclined roof, the minimum distance between collectors and the roof edge is 1m.

The 2,52m² and 2.65m² type for vertical installation.

Approx. 2560 mm height and 1320 mm width is required the first collector + 1220 mm width for each consecutive one. In case of mounting collectors on the inclined roof, the minimum distance between collectors and the roof edge is 1m.

The 2.65m² type for horizontal installation.

Approx. 1320 mm height and 2560 mm width is required the first collector + 2510 mm width for each consecutive one. In case of mounting collectors on the inclined roof, the minimum distance between collectors and the roof edge is 1m.

3.7 The warranty conditions for the installation and use of the collectors are set out in the warranty card

3.8 Use of collectors in coastal areas.

- For collectors installed at up to 500m from the seashore, there is no warranty for the absorber with highly selective coating.

The use of collectors with an absorber with increased resistance to sea water, e.g. Mirosol TS, is recommended.

4. Spacing of tile holders



Tip

The values of spacing for tile holders provided below are only rough values and they should be observed approximately.

In case of corrugated tiles, the factor which essentially determines the spacing of holders is the arrangement of hollows on the roof surface.

Number and spacing of tile holders

Two pairs of tile holders (top and bottom) are required for the first collector. For each successive collector, another pair of holders should be used.

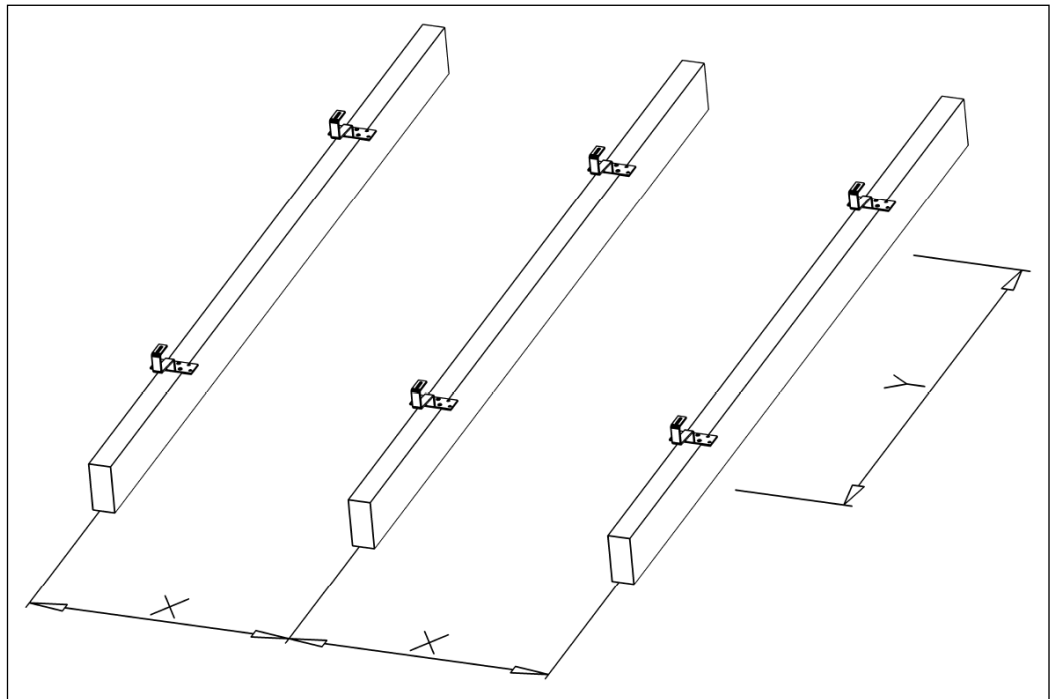

4.1 Horizontal distance between tile holders – X

No of collectors	No of holders	Distance X between tile holders [m]		
		2.02m ² collector, vertical	2.52m ² 2.65m ² collector, vertical	2.65m ² collector, horizontal
1	4	0.806	0.920	1.956
2	6	0.956	1.070	2.233
3	8	1.006	1.120	2.325
4	10	1.031	1.145	2.371
5	12	1.046	1.160	2.399

4.2 Vertical distance between tile holders – Y

The distance between the upper and bottom section should be within:

2.02m², vertical: Y = 1510 – 1860 mm

2.52m², vertical: Y = 1750 – 2100

2.65m², vertical: Y = 1860 – 2210 mm

2.65m², horizontal: Y = 830 – 980 mm

5. Installation on the inclined roof

5.1 Installation of tile holders

The first step is to mount the tile holders following the guidelines in section 4. Spacing of tile holders.

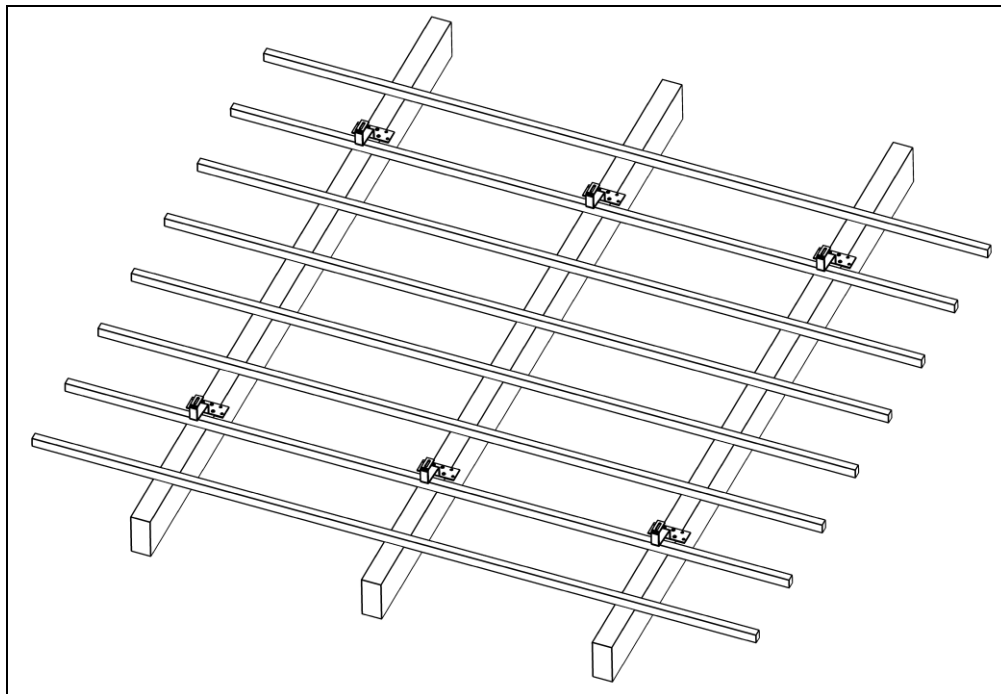

- insert a row of tiles under those that are above,
- at the planned height, screw the provided tile holders to the rafter (4 screws of 6x40),

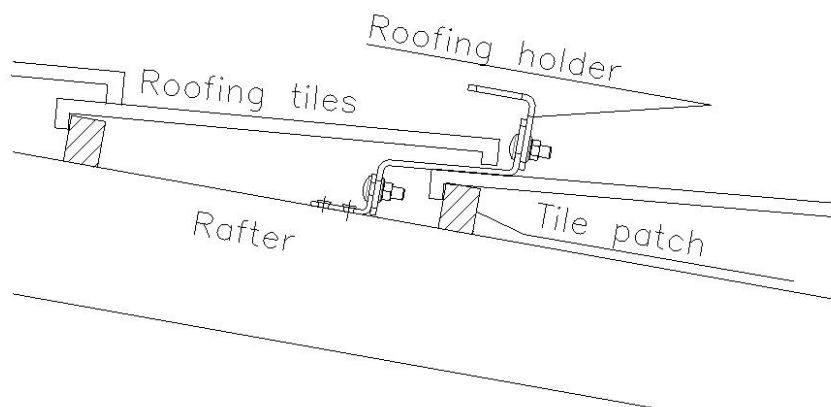

- the tile holders should be fixed to a tile so that the supporting part is located in its hollow (for corrugated roofing tiles).

To make the above-mentioned adjustment, screw the tile holders to the rafter using the configurations as shown below:

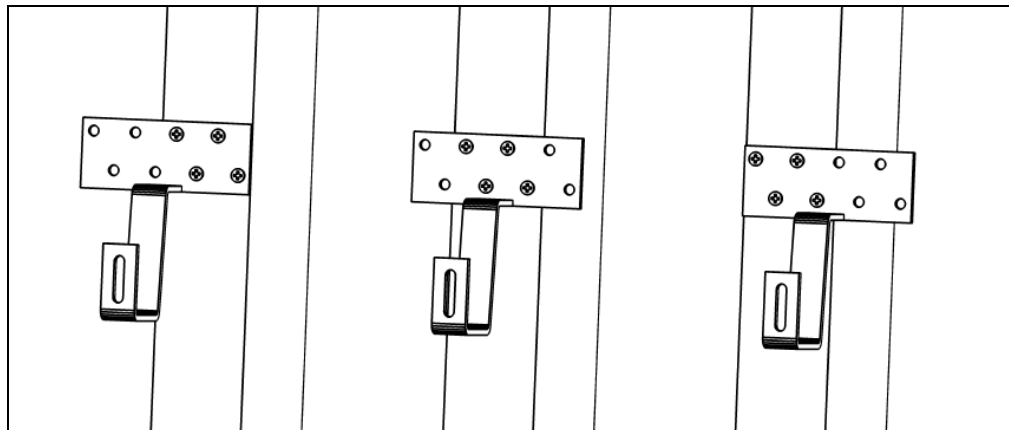

- restore the tiles moved for the purposes of the installation to their original state.

5.1.1 Installation of tile holders in case when the spacing of roof rafters does not correspond to the required spacing of the tile holders (section 4)

If the spacing of roof rafters does not correspond to the required spacing between the roofing tiles, the installer must reinforce the space between the rafters on his own to allow mounting the tile holder.

It is recommended to reinforce the lath with a cross-section of min 40x60mm bolted to two mounting brackets (min 80x80x60x3 mm), which are then fastened to the two roof rafters.

The upper edge of the reinforcement should be aligned with the upper edge of the rafter.

The elements necessary to make the reinforcement (lath, mounting brackets and screws) are not included in the mounting set.

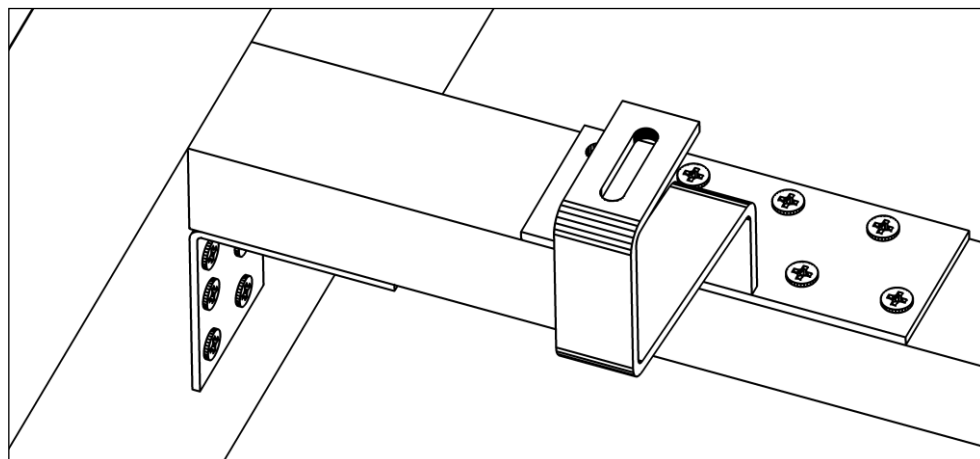

5.2 Mounting a collector on the tile roof.

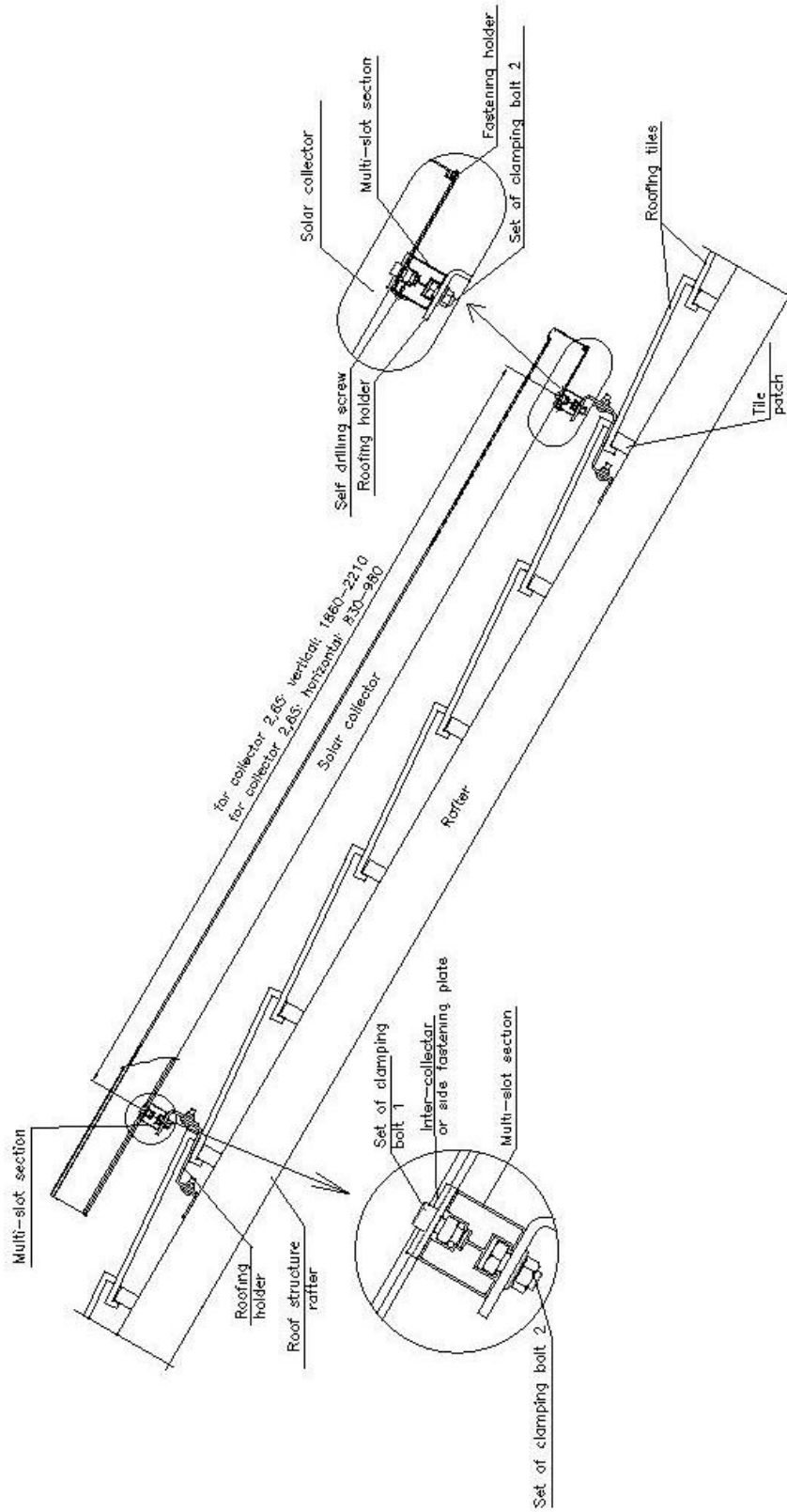

5.3 Joining of multi-slot sections

The mounting set includes the suitable number of multi-slot sections according to the number of collectors.

The table below provides the total number of sections for the set of upper and bottom sections.

No of collectors	2.02m ² collector, vertical		2.52m ² collector, 2.65m ² collector, vertical		2.65m ² collector, horizontal
	Section 1120 mm	Section 2240 mm	Section 1230 mm	Section 2460 mm	Section 2495 mm
1	2 pcs.	-	2 pcs.	-	2 pcs.
2	-	2 pcs.	-	2 pcs.	4 pcs.
3	2 pcs.	2 pcs	2 pcs	2 pcs	6 pcs.
4	-	4 pcs.	-	4 pcs.	8 pcs.
5	2 pcs.	4 pcs	2 pcs.	4 pcs	10 pcs.

Multi-slot sections should be joined in accordance with the configuration table as in the photo below:

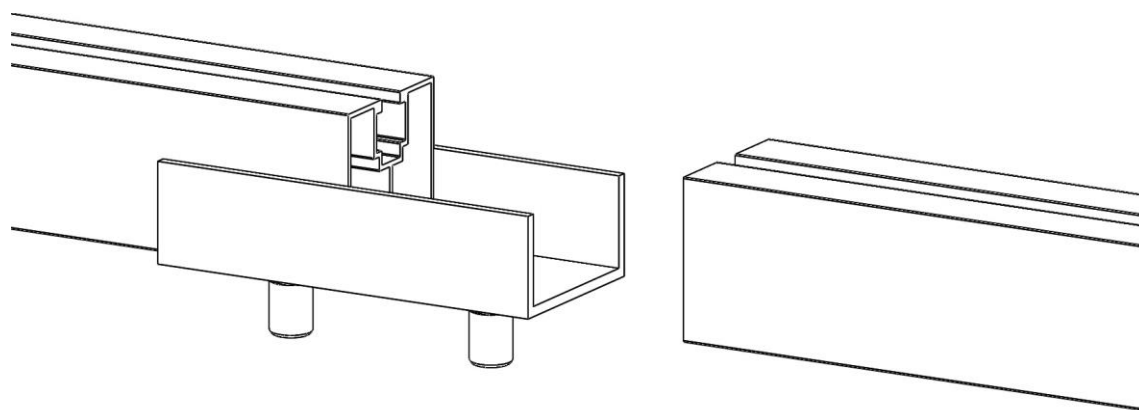

Tip



To avoid an uncontrollable dislocation of the connector, you can use screws M10x20.

- place the connector at a distance of 50mm from the profile edge
- use the provided fastener to connect the sections with each other.

5.4 Connection of multi-slot sections with tile holders.

Connection of multi-slot section with tile holder.

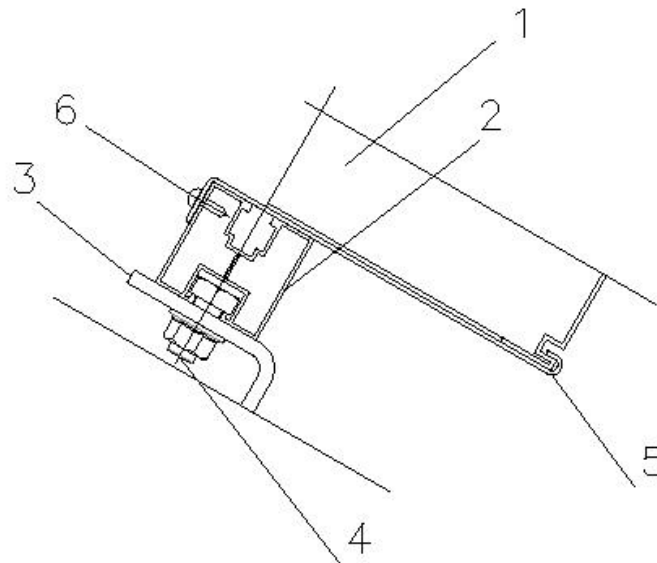

- 1 – collector
- 2 – multi-slot section
- 3 – tile holder
- 4 – nut and washer
- 5 – collector fastening holder
- 6 - self drilling screw

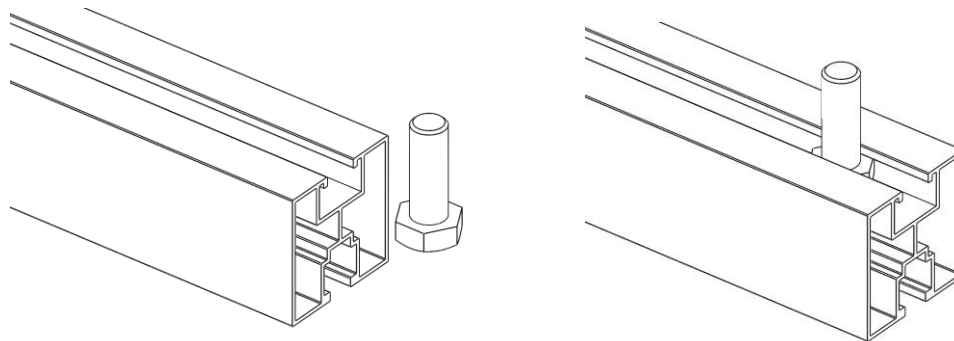

- place the clamping bolt inside the multi-slot section as shown in the drawings,

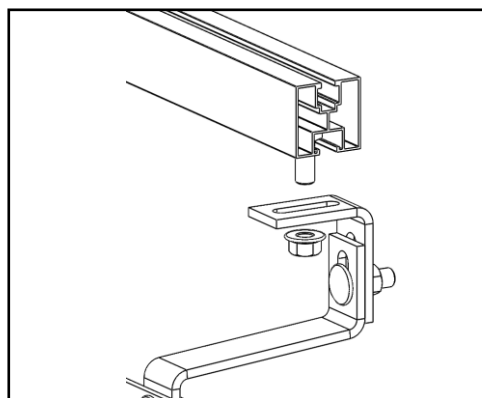

- use the nut to screw it slightly with the tile holder,
- position the multi-slot sections according to 5.5.

5.5 Positioning of multi-slot sections.

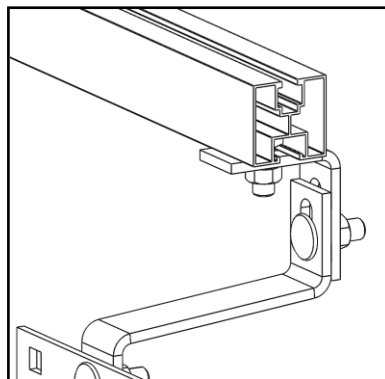
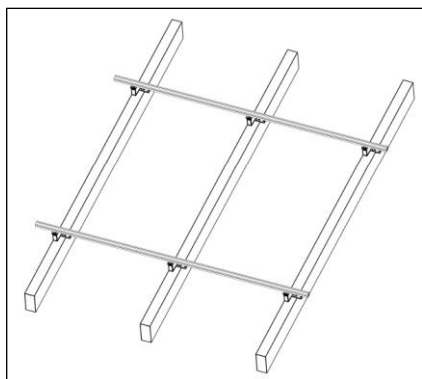

- the sections should be mounted parallel to each other and the edges of the upper and the lower section should be aligned,
- when the sections are positioned, tighten the bolts.



Tip

Use a level and e.g. a ridge beam to properly position the sections.

5.6 Assembly of collector fastening holders.

5.6.1 Mounting a collector on the multi-slot section.

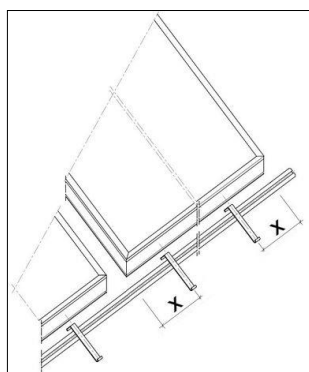

Each collector should rest on two fastening holders which protect it against sliding down.

The fastening holders should be located at the distance of $x = 200-250$ mm from the edge of the collector.

5.6.2 Assembly of collector fastening holders.

The collector fastening holders should be mounted in the upper gap of the bottom multi-slot section and counter it with a self-drilling screw as in the drawings.

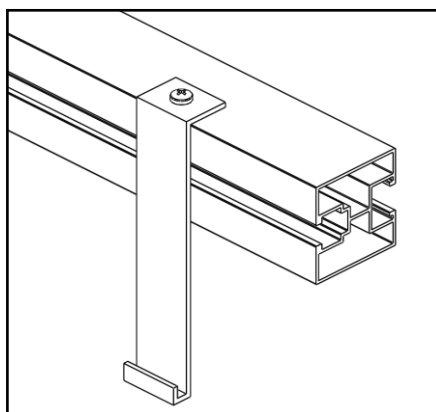

5.7. Installation of the correction set for the mounting set on the inclined roof covered with tiles (optional version)

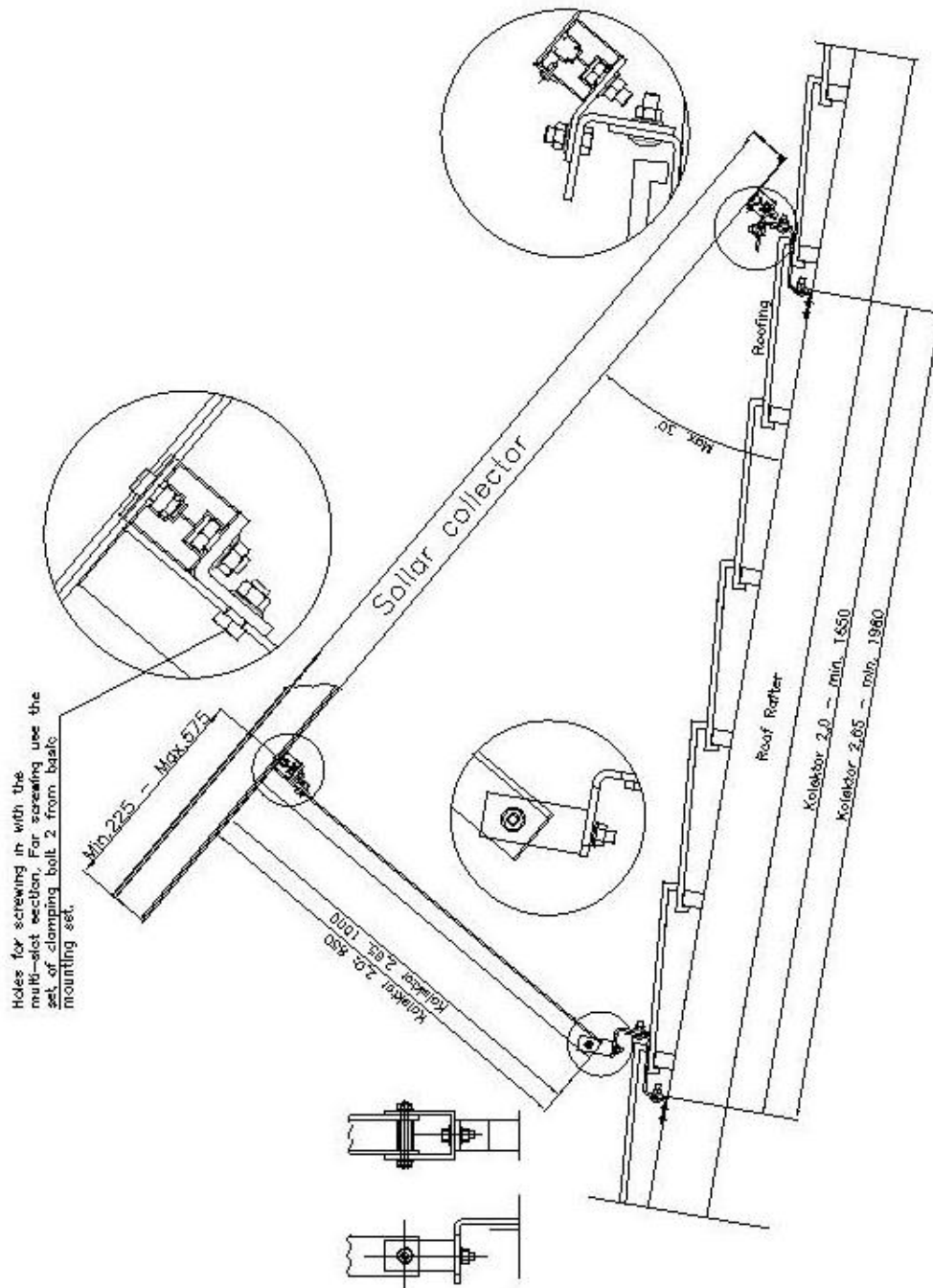

NOTE:

All dimensions are approximate values and depend on the installation capabilities on the roof. You must not exceed the max/ min dimensions given in the drawing! The more the structure dimensions are similar to the values given in the drawing the less deviation from the expected correction of 30° angles is.

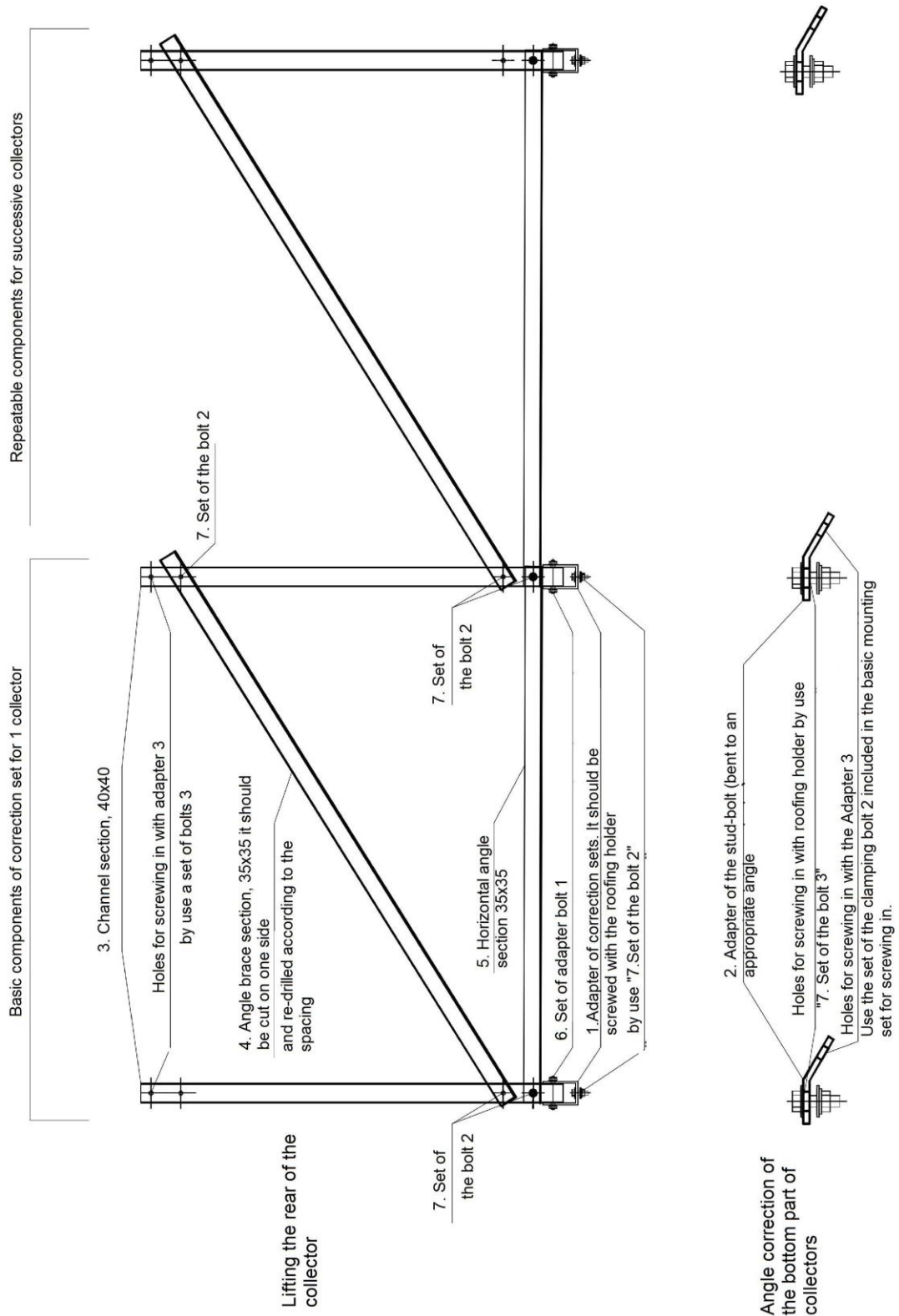

5.8. Installation of collectors

5.7.1 Installation of collectors on the supporting structure using the pipe union set

During the installation of collectors you must follow all safety instructions.



Hazard

- take the appropriate precautions when working on the roof to avoid accidents,
- when working on the roof you should always be protected against falling,
- the installation should be carried out by at least two persons,
- wear protective clothing during the works,
- after completion of the installation works check that the mounting set and the collectors have been installed in a stable manner.



Tip

During transport and installation, collectors should be protected against falling.

There are four fasteners for each collector, two on each section.

- Insert nuts in the sections; two per collector,
- place the collector on multi-slot sections in such a way that it is supported on the bottom fastening holders,
- connect the collectors hydraulically by means of an expansion joint,
- mount the fastening plates at the bottom gap of the collector's frame, screw the bolt with the nut located in the section as shown below.

Single fastening plates are provided for at the edges, and between collectors double plates are used.

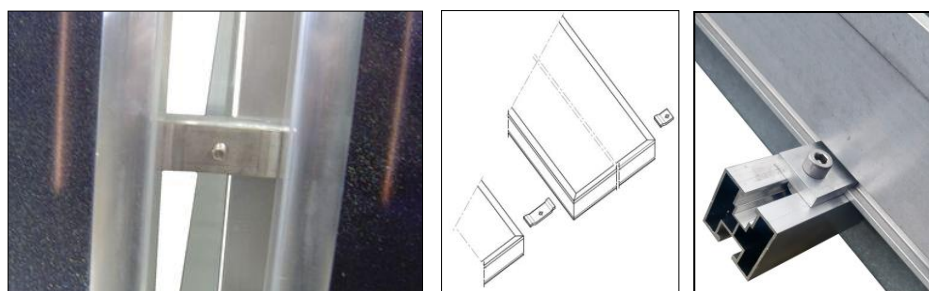

5.8.2 Installation of collectors on the supporting structure using the threaded union set

There are four fasteners for each collector, two on each section.

- Insert nuts in the sections; two per collector,
- place the collector on multi-slot sections in such a way that it is supported on the bottom fastening holders,
- connect the collectors hydraulically by means of an expansion joint,
- mount the fastening plates at the bottom gap of the collector's frame, screw the bolt with the nut located in the section as shown below.

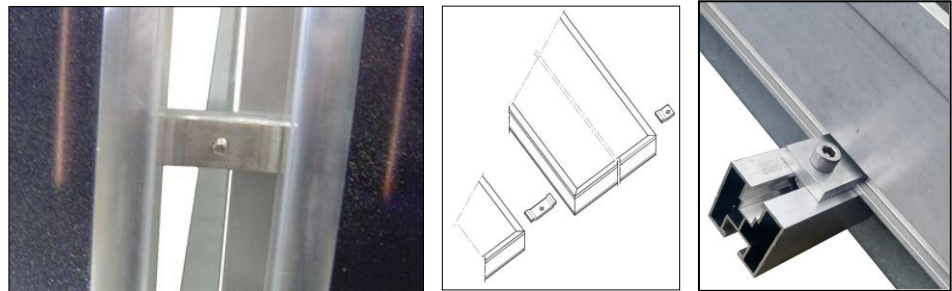

Single fastening plates are provided for at the edges, and between collectors double plates are used.



PMB35



PMM112



PMM79

In place of the threaded union, insert the PMM79 inter-collector plate, which sets the distance between collectors = 67mm. In place of the pipe union, use the PMM112 inter-collector plate, which sets the distance between collectors = 100mm.

In case of installation of the battery for 4 or 5 collectors, the pipe union should be mounted between the 2nd and 3rd collector.

6. Hydraulic connection of collector

CAUTION!

ALL CLAMPING CONNECTIONS
SHOULD BE TIGHTENED WITH A TORQUE OF
45 – 50 Nm
AND LOCKED

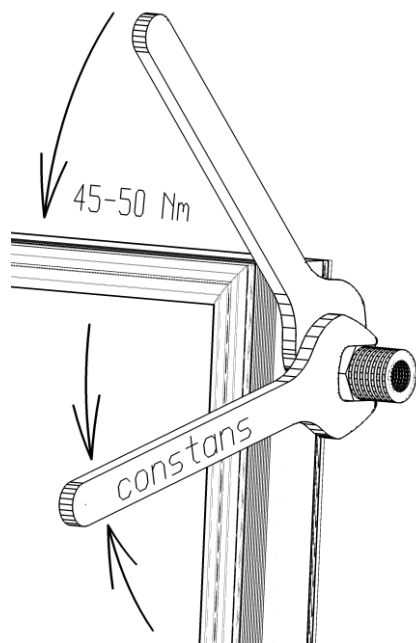

The counter torque wrench with the connector cannot change its position when tightening!

In case of leakage, tighten the clamping connections with a torque of max 80 Nm.

In the event of further leaks, use the Loxeal 8672 sealant according to the instructions on the package.

6.1 Connection of double-harp collectors



Tip

The hydraulic hoses and fixtures can be connected at the left or right side of the collector battery. The manual presents the right-hand side connection as an example.

Connection of max 5 collectors

When joining collectors into one battery, max 5 collectors can be used at the same time.

6.2 Connection of meander collectors



Tip

The supply line^{*1} and the return line^{*2} must be connected diagonally across the collector or battery. The supply line^{*1} should be connected to the lower connector pipe and the return line^{*2} with a vent to the top one. The connection for the supply line^{*1}/return line^{*2} is arbitrary – in can connected on the left or right-hand side. Insert clamping plugs in the two other connector pipes. The manual presents the connection of the supply line^{*1} at the right-hand side and the return line^{*2} at the left-hand side as an example.

Connection of max 10 collectors

When joining collectors into one battery, max 10 collectors can be used at the same time.

*1 – supply line = inlet of cold fluid *2 – return line = outlet of heated fluid

6.3.1 Connection of collectors with a clamping pipe union.

Double-harp collectors – connection of upper connector pipes

Meander collectors – connection of bottom and upper connector pipes

1. connector pipe of the collector
2. strengthening sleeve
3. pipe union nut
4. clamping ring
5. pipe union body

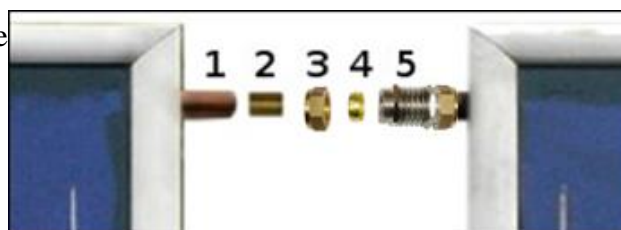

Place the pipe union on the first collector, move the second collector closer and screw the pipe union on both collectors.

- the strengthening sleeve (2) is factory mounted in the connector pipe of the collector (1),
- place the pipe union nut (3) on the connector pipe of the collector (1),
- place the clamping ring (4) on the connector pipe of the collector,
- screw the nut (3) on the pipe union body,
- place the strengthening sleeve in the connector pipe of the second collector,
- place the nut on the connector pipe of the second collector,
- place the clamping ring on the connector pipe of the second collector,
- move the second collector closer to the pipe union,
- screw the nut on the pipe union body.

Tip

The nut should be tightened so as to ensure tight connection, however using the appropriate torque to avoid damage to the connector pipe of the collector.



6.3.2 Connection of the collector's supply line*1

1. connector pipe of the collector
2. strengthening sleeve
3. nut
4. clamping ring
5. elbow body
6. silicone gasket
7. insulated flexible hose

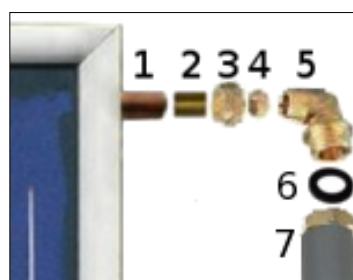

- the strengthening sleeve (2) is factory mounted in the connector pipe of the collector (1),
- place the pipe union nut (3) on the connector pipe of the collector (1),
- place the clamping ring (4) on the connector pipe of the collector (1),
- screw the nut (3) on the elbow (5),
- place the silicone gasket (6) in the nut of the flexible hose (7),
- screw the nut of the flexible hose (7) on the elbow (5),
- connect the flexible hose to the solar system.

*1 – supply line = inlet of cold fluid

6.3.3 Connection of the collector's return line*2

1. connector pipe of the collector
2. strengthening sleeve
3. press nut
4. clamping ring
5. complete cross fitting with a manual vent and immersion sleeve
6. silicone gasket
7. insulated flexible hose



- the strengthening sleeve (2) is factory mounted in the connector pipe of the collector (1),
- place the press nut (3) on the connector pipe of the collector (1),
- place the clamping ring (4) on the connector pipe of the collector (1),
- place the immersion sleeve with a complete cross fitting (5) in the connector pipe of the collector (1),
- screw the press nut (3) on the cross fitting (5) on the left-hand side,
- place the silicone gasket (6) in the nut of the flexible hose (7),
- screw the insulated flexible hose (7) on the cross fitting (5) from the bottom.
- connect the flexible hose to the solar system.

6.3.4 Optional solution – installation of automatic vent

Where necessary, you can install the automatic vent with a valve and adapter in place of the manual vent.

- 7 – ¾" x ⅜" adapter,
- 8 – ⅜" ball valve,
- 9 – ⅜" automatic vent



- unscrew from the cross fitting (5), manual vent
- screw the following at the top of the cross fitting (5): adapter (7), valve (8) and automatic vent (9)



Tip

Due to high temperatures in the solar systems, it is necessary to use vents made completely of metal.

6.3.5 Mounting the clamp plugs – for meander collectors

Mount the clamp plugs on free connector pipes (diagonally across the collector or battery).

- 1 – clamp plug
- 2 – solar collector

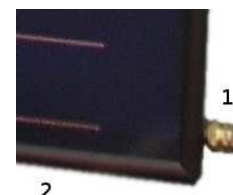

- the strengthening sleeve is factory mounted in the connector pipe of the collector,
- place the press nut on the connector pipe of the collector,
- place the clamping ring on the connector pipe of the collector,
- place the clamp plug in the connector pipe of the collector,
- screw the press nut on the clamp plug.

*2 – return line = outlet of heated fluid

6.4 Installation of the O-ring connecting system



6.4.1 Instructions for installation of connection elements

- Place one piece of O-ring on the end of the connection elements (plug, elbow, pipe union)
- Place the connecting system element with O-ring inside the collecting pipe
- Then mount the clip in place of the flange and tighten it using the bolt provided

6.5 Connection of temperature sensor in clamp- and O-ring-type connecting systems (except for hybrid collector)

Damage to the system

In case of wrong installation of the temperature sensor or a damage to the signal cable, there is a risk of damage to the system.



-the signal cable should be protected against damage (e.g. damage caused by birds, rodents) by using a protective pipe.

The temperature sensor should be installed in the immersion sleeve

- insert the sensor all the way into the immersion sleeve,
- protect against moving out using the clamping spring provided.



6.6 Connection of temperature sensor in the hybrid collector



Instructions for installation of the temperature sensor

- place the sensor in a specially located sleeve mounted under the Ø22mm pipe (not in the lateral joint as in case of flat collectors),
- after mounting the sensor in the sleeve (approx. 26 cm), stabilise the sensor cable using the bolt.

6.7 Connection of collecting pipes

The hydraulic connection with collecting pipes should be made using an insulated flexible hose. **The rigid collecting pipes must not be connected directly to the collector.**

The connection of flexible hoses with the system should be made below the vent level.



Tip

The universal roof ventilators and antenna penetrations should be used to pass the hoses through the roof.



Tip

The temperature sensor cable should be laid together with the flexible return line.

7. Final works

7.1 Inspection of the system

Upon completion of the installation works, it is necessary to:

- check all system elements for correct assembly,
- perform the pressure test of the system,
- flush the system,
- fill up the system with the solar agent.

After the pressure test and flushing, you must immediately fill up the system with the solar agent. Otherwise, the tightness test and flushing need to be carried out directly before filling up the system with the solar agent.

7.2 Filling up the system

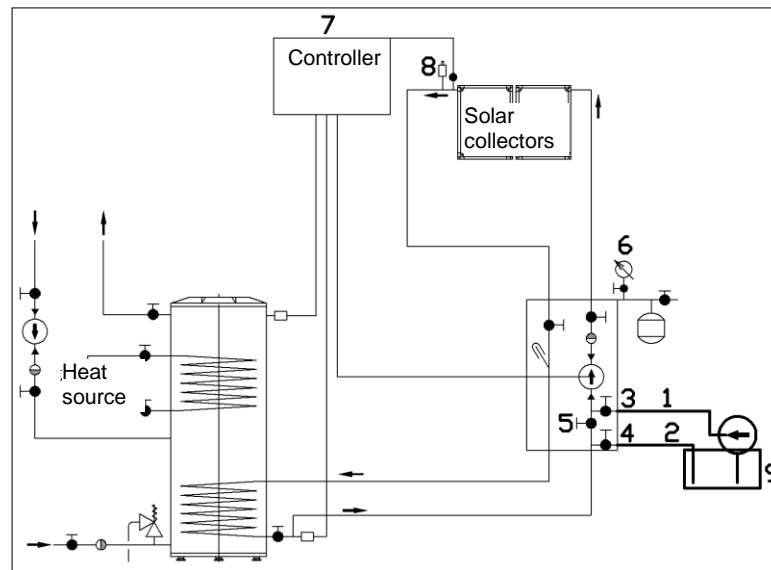

Filling up the system with heat carrier using the filling station.

- Connect the hoses of the filling station (9): the delivery hose (1) with the upper drain valve (3) and the overflow hose (2) with the bottom drain valve (4).
- Fill up the filling station tank with the heat carrier, open the drain valves (3 and 4) and run the impeller pump.
- Close the ball valve (5) to make the fluid flow through the solar collectors. Open and close the ball valve (5) several times when filling up and venting the system,
- Do not turn off the impeller pump until the system is completely vented, i.e. until the moment when air bubbles stop flowing from the hose.
- Open the ball valve (5) and close the drain valve (4), and continue pumping the heat carrier into the system until the required pressure is reached, $p = 2,5$ bar, as indicated by the pressure gauge (6).
- Insert the controller plug (7) to the $\sim 230V$ mains and run the circulation pump in the manual mode.
- The trapped air should be removed automatically by opening the manual valve (8).
- In case of reduced flow or lack of flow (the flow regulator float has gone down), unscrew the central screw of the circulating pump and release the air that blocks the pump. Perform this operation until the system is completely vented.
- In the event when pressure on the pressure gauge (6) has dropped below 1.5 bar, pressurise the system to the required level of $p=2.5$ bar.
- Disconnect the filling station hoses from the valves (3 and 4).

7.3 Venting of the system

After venting of the system by means of the filling station and manual vent, close the vent valve or the ball valve in case of the automatic vent.

7.4 Insulation works

The insulation works should be done after all inspection operations have been completed.

Tip

- High temperature- and weather-resistant insulation must be used to insulate the hoses outside the building.

If necessary, protect the insulation against damage caused by birds.

- High temperature-resistant insulation must be used to insulate the hoses inside the building.



7.5 Mounting the masking section – accessory*

Mounting instructions for the masking section.

The masking section (1) is mounted between the collectors (2) with three fixing elements (3).

Use the clamping bolt (4) to screw the fixing elements (3) to the masking section (1). Arrangement of the fixing elements: two elements at approx. 20cm from the edge of the masking section, and the third one should be placed in the middle of the masking section.

Compress the fixing elements (3) and place them one by one in the upper space between the collectors (2).

Press evenly on the masking section (1) over its entire length until the latch of the fixing element (3) clicks into place in the lower pockets of the collectors (2).

**The masking section is not included in the basic set. It can be ordered as an extra option.*

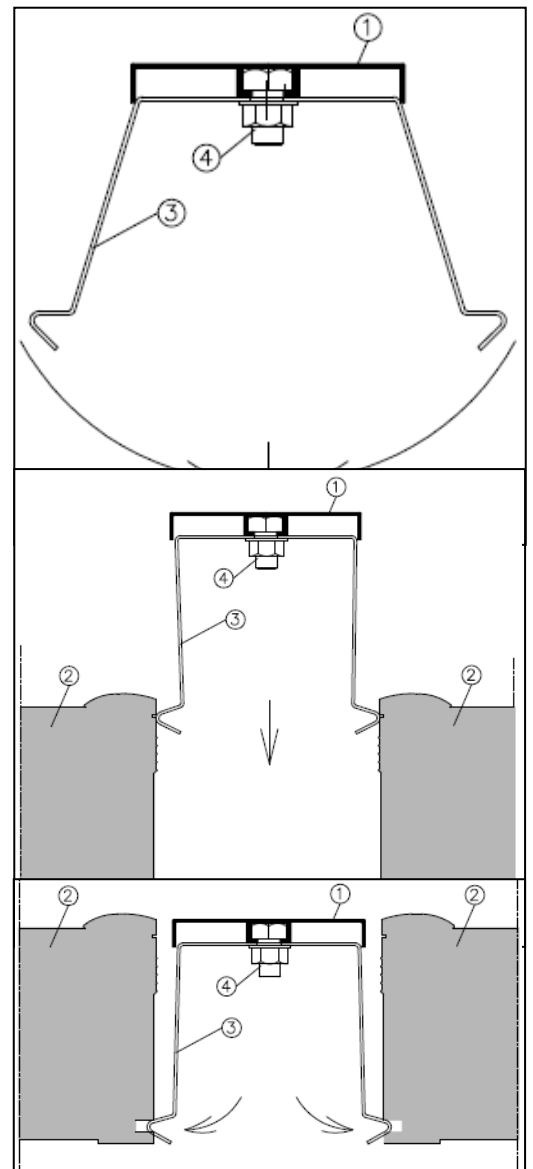

8. Maintenance and service.

- During the maintenance and other works, the collector must be held in a stable position to exclude the danger of tripping over and falling down.
- It is not allowed to make any repairs and maintenance works under a collector, which is raised and not protected against falling down.
- The repair and maintenance works should be done with use of suitable tools and the service personnel should wear protective gloves and shoes.
- Before the maintenance works, it is necessary to wait until the collector temperature drops to a level at which you will not scald your fingers or hands.
- The solar system should be inspected in accordance with the warranty recommendations for individual components of the system.

To ensure a failure-free operation of the whole system, it is recommended to carry out the following maintenance works at least once a year:

- Frost protection – check the solar fluid for resistance to freezing using the control device (refractometer). In case of significant reduction in frost resistance of the solar fluid, replace it and vent the system again.
- System pressure – working pressure in the solar system needs to be checked. After the start-up period, no drop in pressure is permitted.
- Expansion vessel – the input pressure of the expansion vessel should be checked. To do so, disconnect the vessel from the system and measure the pressure. The input pressure should be 2.5 bars.

The control and safety system as well as the structure for supporting or mounting the collectors on the roof should also be inspected.

To guarantee proper operation of the entire system, we recommend you to sign a service contract with a specialist installation company.

Copyrights: Energetyka Solarna Ensol Sp. z o.o.

Copying, reproduction and use of this document or parts thereof without the consent of the authors is strictly forbidden.