

# **Installation instruction for flat solar collectors on flat roof or foundation**

**07/2019**

**Read before installation**



## The installation instruction applies to collectors:

Flat collector	Installation setting	Absorber type	Absorber material *1	width	height	depth	Collector mass	Surface	Connecting system	Liquid content	Optimal flow min. – max.	Stagnation temperature
symbol	-	-	-	A	B	C	m	S	-	V	m	TS
jednostka	-	-	-	mm	mm	mm	kg	m <sup>2</sup>	-	dm <sup>3</sup>	dm <sup>3</sup> /h	°C
<b>ES2V/2,65 Al-Cu</b>	vertical	meander	Al-Cu	1120	2356	85	49	2,65	clamp	2,20	75 - 105	192
<b>ES2V/2,65</b>	vertical	meander	Cu-Cu	1120	2356	85	49	2,639	clamp	2,20	75 - 105	201,5
<b>ES2V/2,52 Al-Cu</b>	vertical	meander	Al-Cu	1120	2250	85	48	2,52	clamp	2,10	75-105	210
<b>ES2V/2,52 Al-Al</b>	vertical	meander	Al-Al	1120	2250	85	47	2,52	o-ring v.l.	2,10	75-105	210
<b>ES2V/2,0 HE</b>	vertical	meander	Cu-Cu	1006	2008	85	40	2,02	clamp	1,80	60 – 90	193,7
<b>EM2V/2,0 Al-Cu</b>	vertical	meander	Al-Cu	1006	1988	85	40	2,0	clamp	1,80	60 - 90	190,3
<b>EM1V/2,0 Al-Cu</b>	vertical	double harp	Al-Cu	1006	1988	85	40	2,0	clamp	1,80	60 - 90	202,3
<b>ES2V/2,0 AL</b>	vertical	meander	Al-Al	1006	2007	85	39	2,19	o-ring v.l.	1,70	60 - 90	185
<b>ES2H/2,65 Al-Cu</b>	horizontal	meander	Al-Cu	2356	1120	85	49	2,65	o-ring v.l.	2,20	75 - 105	192

\*1 Cu-Cu – high-selective sheet=Cu, hydraulic system=Cu;  
Al-Al – high-selective sheet=Al, hydraulic system=Al;  
Al-Cu – high-selective sheet=Al, hydraulic system=Cu.

### Pressure drop in solar collectors.

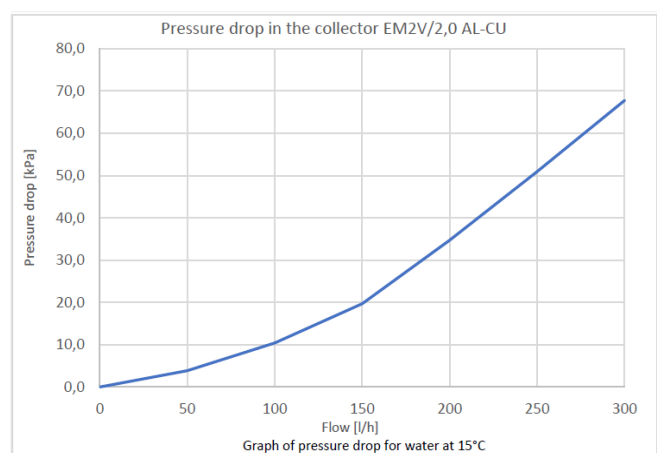
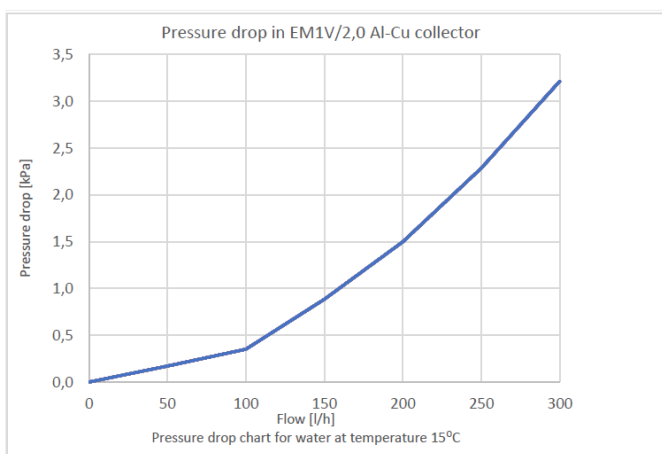

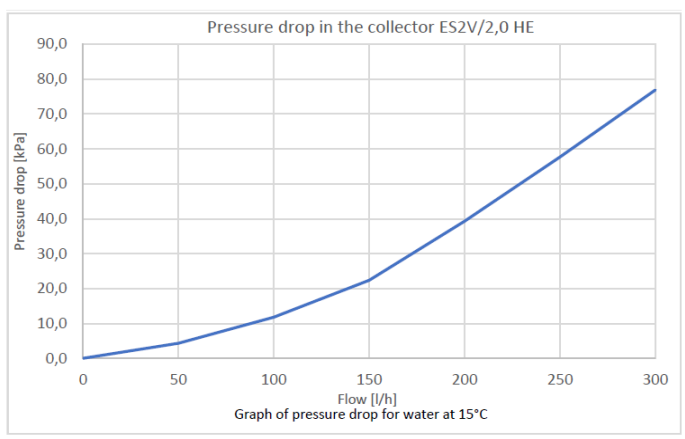
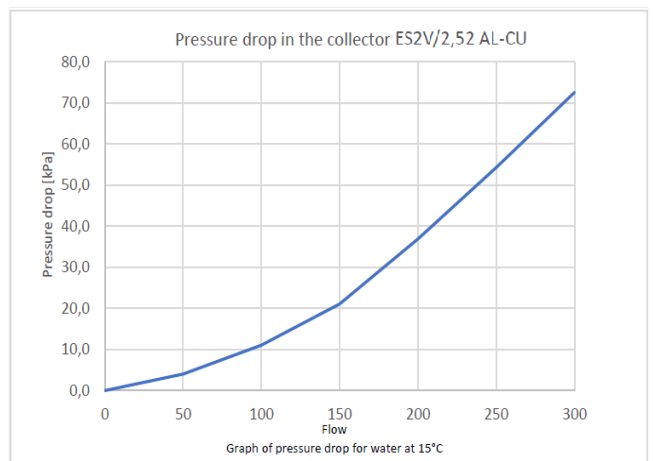
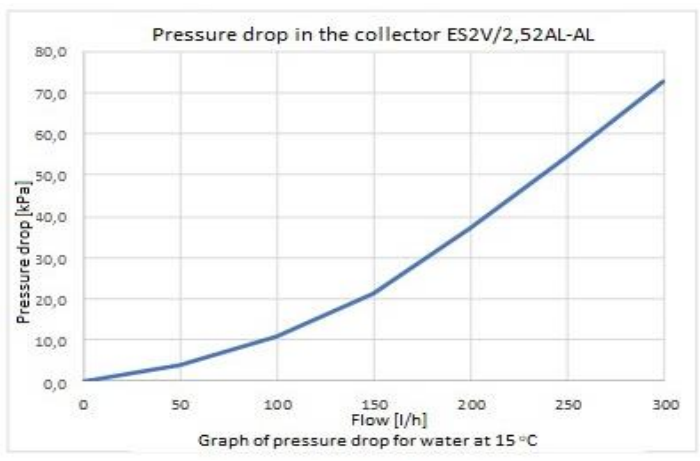
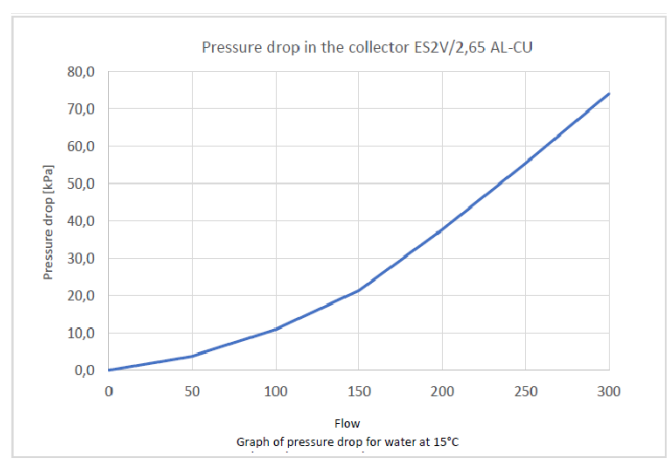
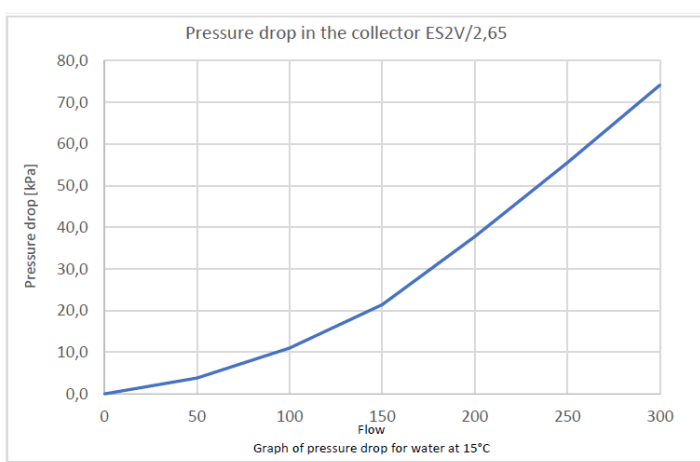
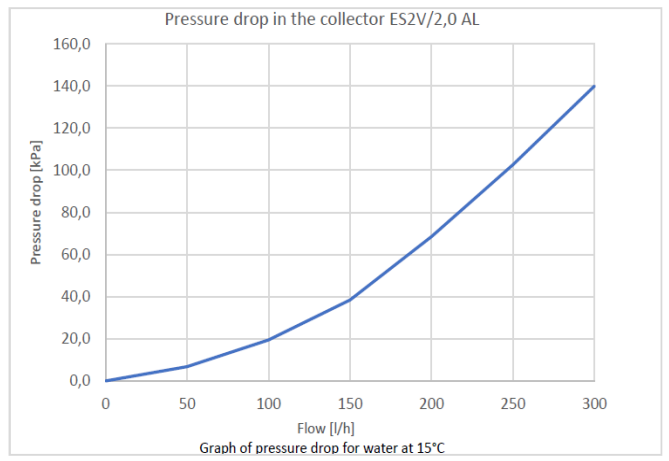
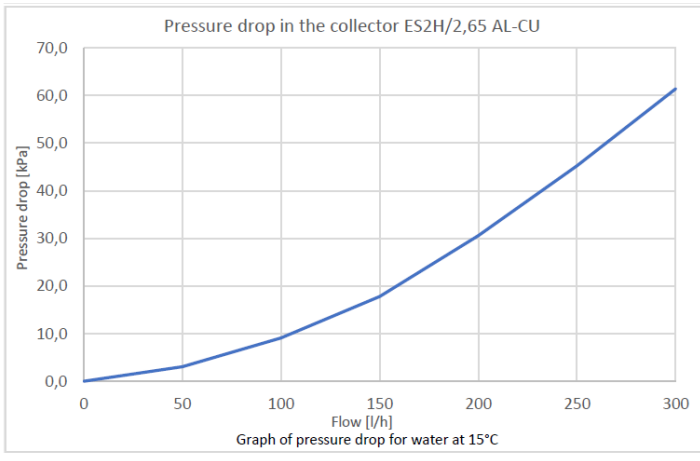

## 1. Introduction



### **Lightning protection installation**

The lightning protection system must be carried out in accordance with the applicable regulations.



### **Recycling**

Worn out solar collectors can be returned to the manufacturer.

The manufacturer will dispose the returned collectors in an environmentally sound manner.

## 2. Safety during installation

**Before starting the installation it is necessary to get promptly acquainted with the safety precautions!**

### **2.1 Notes included in the instruction**

The installation instruction includes important information concerning safety and proper positioning of the collectors on the roof as well as the proper execution of the hydraulic connection.

The drawings and the information included in the instruction apply to a vertical and horizontal installation of collectors.

The installation of collectors described in the instruction may only be performed by qualified persons who have expertise in a range of gas and water installations.

Upon the completion of works, the installer should hand over the installation instruction to the customer and present in a comprehensible manner the principles of operation and Note essential to a proper operation of the solar installation.

### **2.2 Application**

This instruction includes a description of an installation set for installation of collectors on a flat roof or a foundation with the inclination ranging from 30° to 75°.

The installation set shall be used only for solar collectors installation, it must not be used for installation of other devices on the roof. The installation of solar collectors only on a supporting structure guarantees safety.

Collectors installed on the ground must be attached to the ground by the means of foundation and transitional construction (Not included in the standard installation set).

The minimum distance between the bottom edge of a collector to the ground surface must be min.40cm.

## 3. Before installation

### Note



Due to the fact, that installation works on a roof can be dangerous it is recommended to hire a roofing contractor company to carry them out.

### BURN HAZARD

If collectors and installation materials are exposed to solar radiation for a long time, there is a risk of getting burnt on the hot elements.



In order to avoid the danger of getting burnt it is appropriate to:

- use protective clothing,
- cover the collectors and installation elements with a tarpaulin (what limits the heat up from the sun rays).



### Caution!

**If the collectors are packed on a transport pallet vertically, use the following unloading instructions.**

Read the instruction before proceeding to unloading of the vertical collector pallet!

- 1) The first stage before unloading is to set the transport pallet on a flat surface. Figure 1.1 shows the transport pallet set on a flat consolidated foundation
- 2) The second stage of unloading is to put a 30mm high board under the transport pallet so that the inclined transport pallet becomes stable. Figure 2.1 presents the conditions that the transport pallet should fulfill before unloading.
- 3) After fulfilling the conditions for setting the transport pallet, the collectors can be unloaded. Take special caution while unloading (**COLLECTORS ARE PROTECTED ONLY AT THE FRONT OF THE PALLET**). In the picture marked as 3.1, the transport pallet ready for unloading is presented.
- 4) After removing a collector, the next one should be **absolutely protected** until it is unloaded.

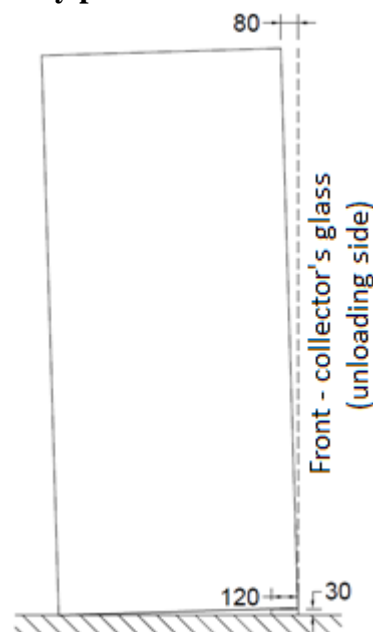

**1.1 Shipment position****2.1 Unloading position****3.1 Transport pallet ready for unloading****3.1 The delivery completeness**

Before installation it is necessary to check if the delivery is complete (see figure below) and the delivered components are not damaged.



- in case of discovering any damages of element or part the replacement of a such should be immediately provided,

- the replacement must be provided only with the application of original spare parts

### 3.1.1 Installation set for vertical collectors can to occur (interchangeably) in one of 3s variants differing in the method of adjusting the angle of inclination.

**3.1.1.A** Installation set for vertical collectors with profile c 40x40, square pipe 40x40 and 35x35. The angle is adjusted by extending the 40x40 square pipe from the 35x35 square pipe.

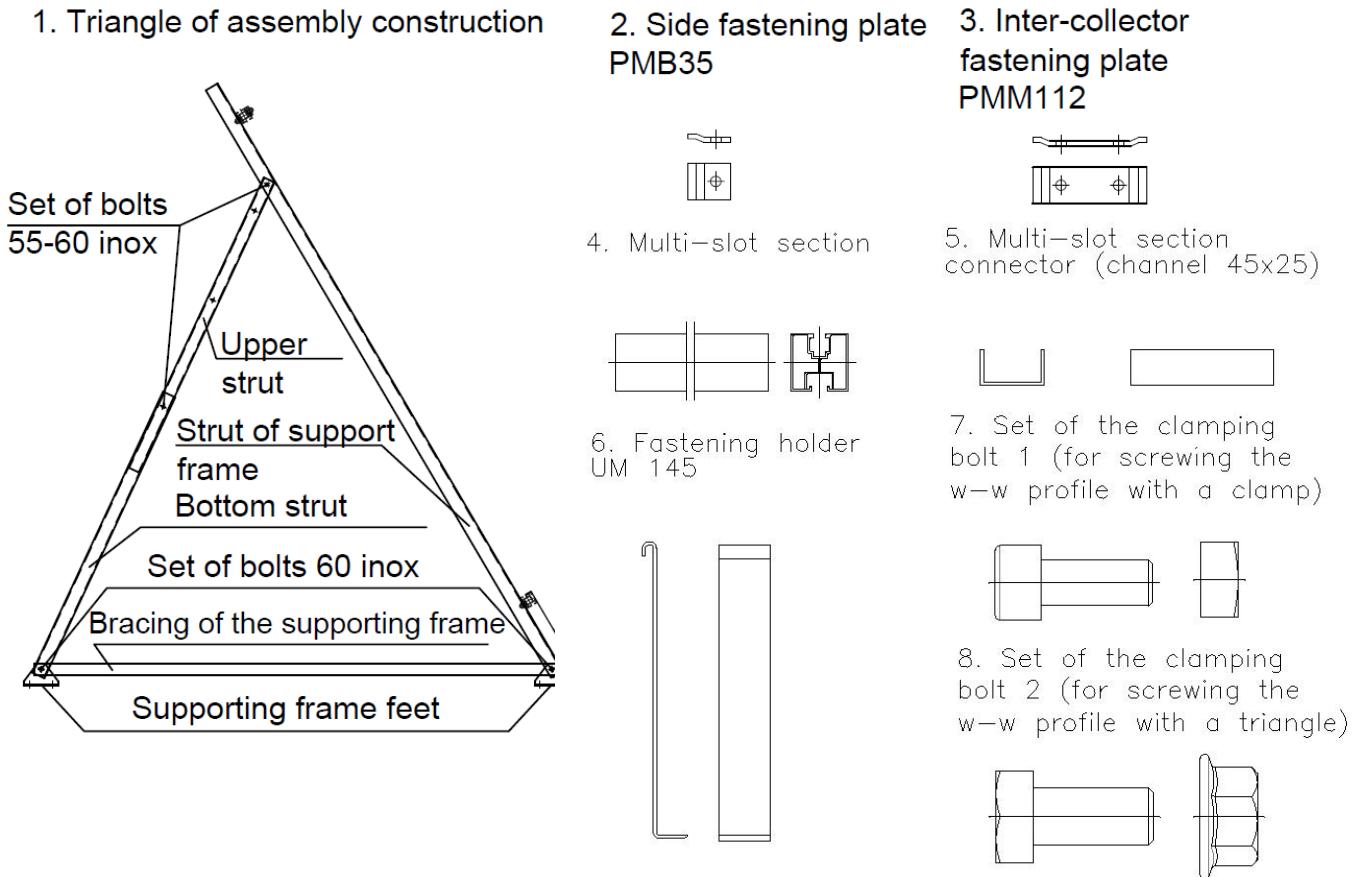

**3.1.1.B** Installation set for vertical collectors based on C-profile 40x40, square pipe 40x40 and 35x35. The angle is adjusted by cutting square pipe 40x40.

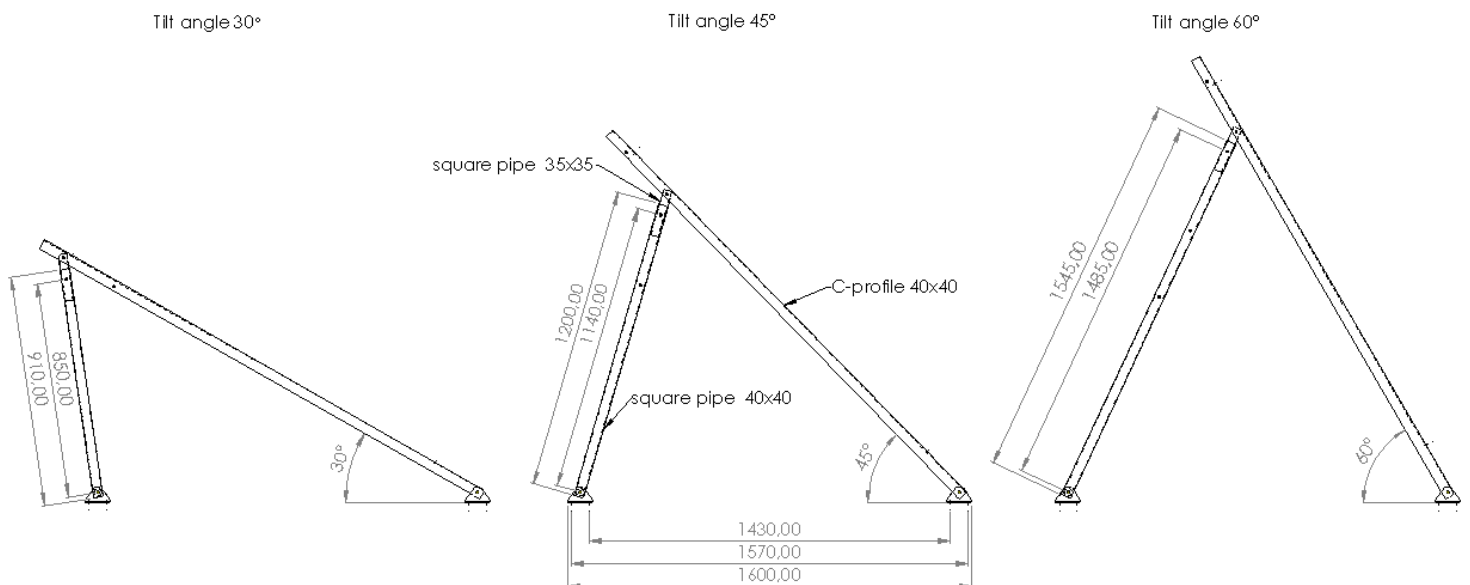

### 3.1.1.C Installation set for vertical collectors based on C-profile 40x40 and square pipe 35x35. The angle is adjusted by cutting square pipe 35x35. (It requires placing wide washers between square pipe 35x35 and the foot of the triangle)

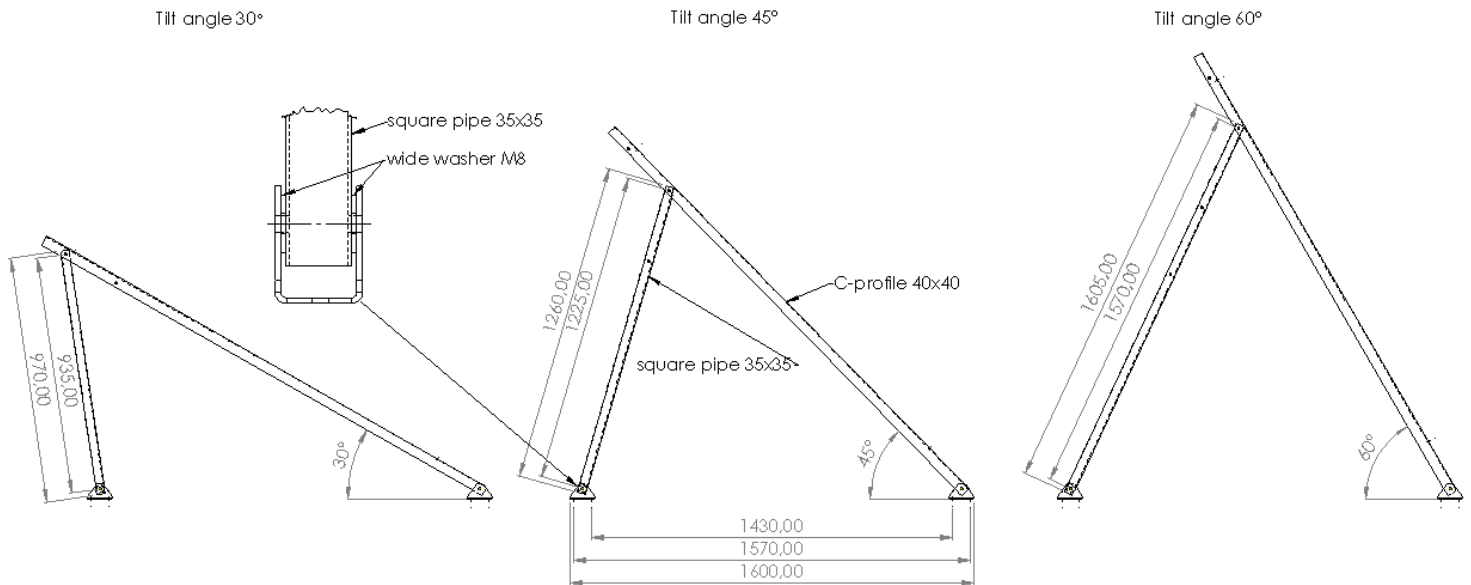

### 3.1.2 Installation set for horizontal collectors

#### 1. Triangle of assembly construction

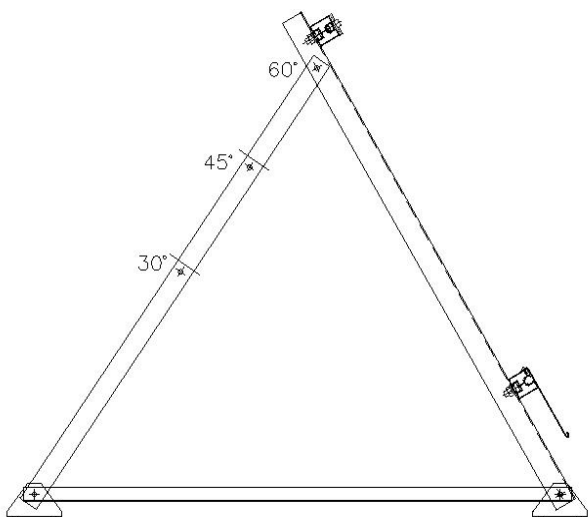

#### 2. Side fastening plate PMB35



#### 4. Multi-slot section

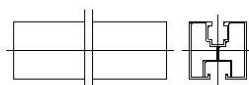

#### 6. Fastening holder UM 145

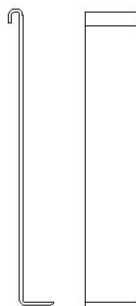

#### 3. Inter-collector fastening plate PMM112

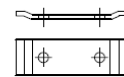

#### 5. Multi-slot section connector (channel 45x25)



#### 7. Set of the clamping bolt 1 (for screwing the w-w profile with a clamp)

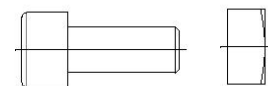

#### 8. Set of the clamping bolt 2 (for screwing the w-w profile with a triangle)

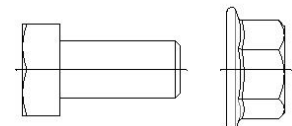



### 3.1.3 Installation set delivery completeness – flat roof / foundation „on compensator”

Flat roof installation set			Battery									
No.	Name	unit	1	2	3	4	5	6	7	8	9	10
1.	Assembly triangle	pc.	2	3	4	5	6	7	8	9	10	11
2.	Side fastening plate PMB35	pc.	4	4	4	4	4	4	4	4	4	4
3.	Inter-collector fastening plate PMM112	pc.	0	2	4	6	8	10	12	14	16	18
4.1	Vertical collectors 2,0m <sup>2</sup> Multi-slot section l=2240	pc.	2*1120	2*2240	2*1120 + 2*2240	4*2240	2*1120 + 4*2240	6*2240	2*1120 + 6*2240	8*2240	2*1120 + 8*2240	10*2240
4.2	Vertical collectors 2,52 m <sup>2</sup> and 2,65m <sup>2</sup> Multi-slot section l= 2460	pc.	2*1230	2*2460	2*1230 + 2*2460	4*2460	2*1230 + 4*2440	6*2460	2*1230 + 6*2460	8*2460	2*1230 + 8*2460	10*2460
4.3	Horizontal collectors 2,65m <sup>2</sup> Multi-slot section l=2500	pc.	2*2500	4*2500	6*2500	8*2500	10*2500	-	-	-	-	-
5.	Fastening holder UM114	pc.	2	4	6	8	10	12	14	16	18	20
6.	Set of the clamping bolt 1	set	4	6	12	16	20	24	28	32	36	40
	- allen screw INOX M8x20											
	- INOX M8 square nut											
7.	Set of the clamping bolt 2 (triangle)	set	4	6	12	14	20	22	28	30	36	38
	-INOX screw M10x20											
	- nut with collar INOX M10											
8.	Self drilling screw	set	2	4	6	8	10	12	14	16	18	20

### 3.1.4 The delivery completeness of Installation set – flat roof / foundation „on pipe union”

Flat roof installation set			Battery				
Lp. No.	Name	unit	1	2	3	4	5
1.	Assembly triangle	pc.	2	3	4	5	6
2.	Side fastening plate PMB35	pc.	4	4	4	4	4
3.	Inter-collector fastening plate PMM112	pc.	0	0	0	2	2
4.	Mounting inter-collector plate PMM79	pc.	0	2	4	4	6
5.1	Vertical collectors 2,0m <sup>2</sup> Multi-slot section l=2240	pc.	2*1120	2*2240	2*1120 + 2*2240	4*2240	2*1120 + 4*2240
5.2	Horizontal collectors 2,52m <sup>2</sup> and 2,65m <sup>2</sup> Multi-slot section l=2460	pc.	2*1220	2*2440	2*1220 + 2*2440	4*2440	2*1220 + 4*2440
5.3	Horizontal collectors 2,65m <sup>2</sup> Multi-slot section l=2500	pc.	2*2500	4*2500	6*2500	8*2500	10*2500
6.	Fastening holder UM114	pc.	2	4	6	8	10
7.	Set of the clamping bolt 1	Set	4	8	12	16	20
	- allen screw INOX M8x20						
	- INOX M8 square nut						
8.	Set of the clamping bolt 2 (triangle)	set	4	6	12	14	20
	-INOX screw M10x20						
	- nut with collar INOX M10						
9.	Self drilling screw	set	2	4	6	8	10

## 3.1.5 Vertical collectors Installation set – light version (economical without inclination angle adjustment and bottom strut positioning spacing of the triangle feet)



The collation applies to the part of the instruction only for installation of collectors with the surface of 2,0m<sup>2</sup> on supporting structure on a roof or flat surface in light version, which is an additional version.

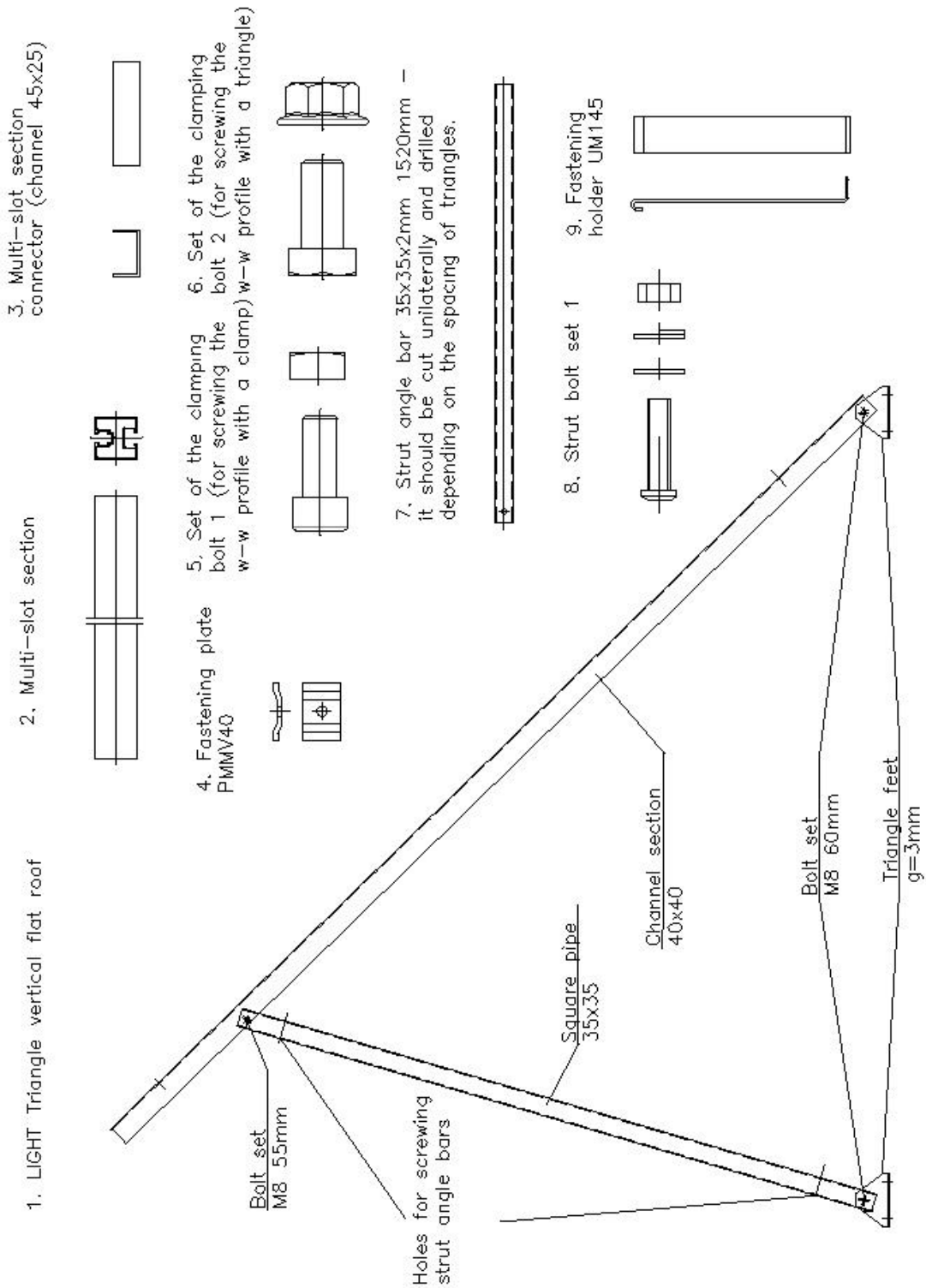

### 3.1.6 The delivery completeness of Installation set for vertical collectors light version „on compensator”.

Installation set – light version			Battery				
Lp. No.	Name	unit	1	2	3	4	5
1	Vertical triangle light flat roof	pc.	2	3	4	5	6
2	Fastening holder UM114	pc.	2	4	6	8	10
3	Multi-slot section Collector 2.0m <sup>2</sup>	lm	2*1,12	2*2,24	2*2,24 + 2*1,12	4*2,24	4*2,24 + 2*1,12
4	Multi-slot section Collector 2.52m <sup>2</sup> and 2.65m <sup>2</sup>	lm	2*1,23	2*2,46	2*2,46 + 2*1,23	4*2,46	4*2,46 + 2*1,23
5	Multi-slot section connector	pc.	-	-	2	2	4
6	Side fastening plate PMB35	pc.	4	4	4	4	4
7	Inter-collector fastening plate PMM112	pc.	-	2	4	6	8
8	Set of the clamping bolt 1	set	4	6	8	10	12
	- allen screw INOX M8x20						
	- INOX M8 square nut						
9	Set of the clamping bolt 2	set	4	6	12	14	20
	-INOX screw M10x20						
	- nut with collar INOX M10						
	<b>Optional elements for light version</b>						
10	Angle strut al.35x35	pc.	1	2	3	4	5
11	Strut bolt set	set	2	3	4	5	6
	- bolt INOX M8x55						
	- nut INOX M8						
	- resilient plate						
	- plate INOX M8						
12	Self drilling screw	set	2	4	6	8	10

### 3.1.7 The delivery completeness of Installation set for vertical collectors light version “on pipe union”

Installation set - light version			Battery				
No.	Name	unit	1	2	3	4	5
1	Vertical triangle light flat roof	pc.	2	3	4	5	6
2	Fastening holder UM114	pc.	2	4	6	8	10
3	Multi-slot section 2.0m <sup>2</sup>	mb.	2*1,12	2*2,24	2*2,24 + 2*1,12	4*2,24	4*2,24 + 2*1,12
4	Multi-slot section Collector 2.52m <sup>2</sup> and 2.65m <sup>2</sup>	lm	2*1,23	2*2,46	2*2,46 + 2*1,23	4*2,46	4*2,46 + 2*1,23
5	Multi-slot section connector	pc.	-	-	2	2	4
6	Side fastening plate PMB35	pc.	4	4	4	4	4
7	Inter-collector fastening plate PMM112	pc.	-	-	-	2	2
8	Inter-collector fastening plate PMM79	pc.	-	2	4	4	6
9	Set of the clamping bolt 1	set	4	6	8	10	12
	- allen screw INOX M8x20						
	- INOX M8 square nut						
10	Set of the clamping bolt 2	set	4	6	12	14	20
	-INOX screw M10x20						
	- nut with collar INOX M10						
	<b>Optional elements for light version</b>						
11	Angle strut al.35x35	set	1	2	3	4	5
12	Strut bolt set	set	2	3	4	5	6
	- bolt INOX M8x55						
	- nut INOX M8						
	- resilient plate						
	- plate INOX M8						
13	Self drilling screw	set	2	4	6	8	10

### 3.1.8 The delivery completeness for clamp connecting system „on the compensator” for double harp collector

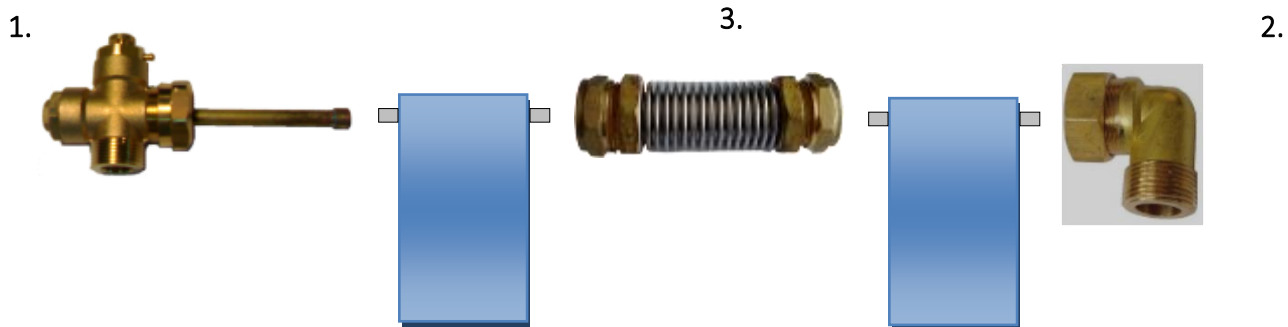

No.	Connecting system for double-harp collectors Name	unit	Battery x				
			1	2	3	4	5
1.	Cross fitting fi22 x GZ3/4” with a vent	pc.	1	1	1	1	1
2.	Clamping elbow fi22 x GZ3/4”	pc.	1	1	1	1	1
3.	Compensator fi22 x fi22	pc.	0	1	2	3	4

### 3.1.9 The delivery completeness for clamp connecting system „on a pipe union” for double harp collector

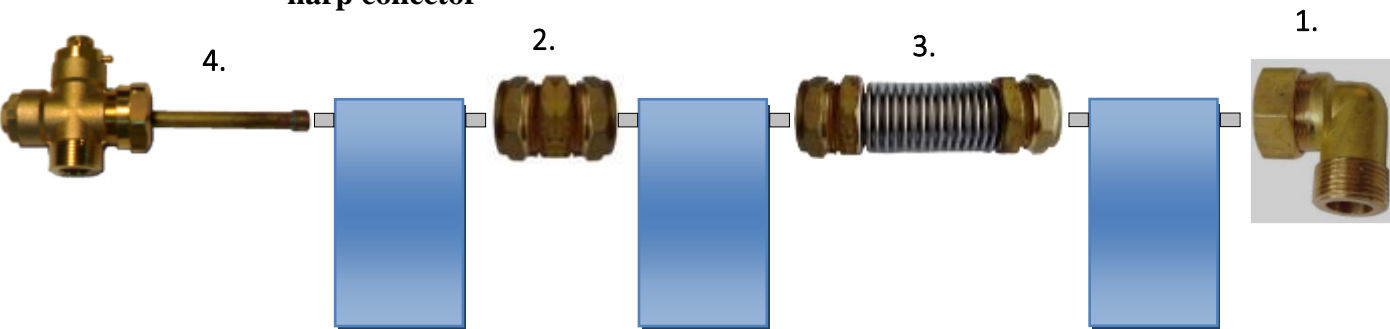

No.	Connecting system for double-harp collectors Name	unit	Battery x				
			1	2	3	4	5
1.	Elbow fi22 x GZ3/4”	pc.	1	1	1	1	1
2.	Pipe union fi22 x fi22	pc.	0	1	2	2	3
3.	Compensator fi22 x fi22*	pc.	0	0	0	1	1
4.	Cross fitting fi22 x GZ3/4” with a vent	pc.	1	1	1	1	1

\*In case of a battery with 4 and 5 collectors, the compensator needs to be placed between 2 and 3 collector.

### 3.1.10 The delivery completeness for clamp connecting system „on the compensator” for a meandric collector – vertical installation

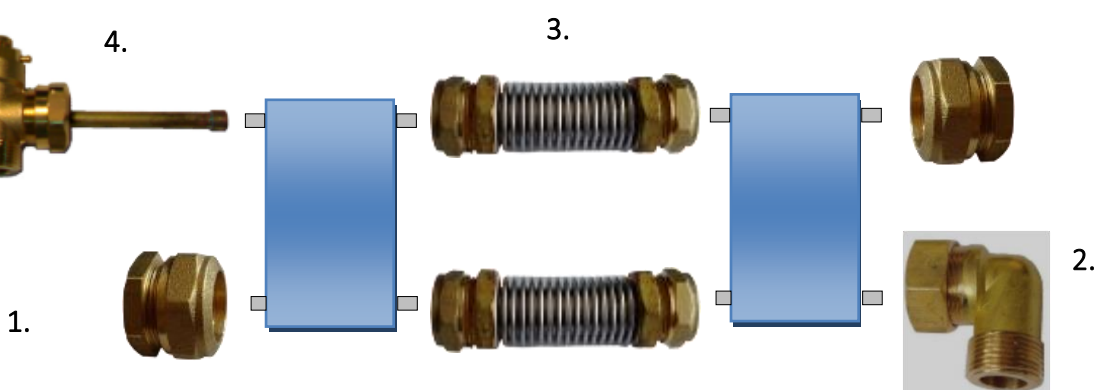

No.	Name	unit	Battery x											
			1	2	3	4	5	6	7	8	9	10		
1.	Clamping end cap fi22	pc.	2	2	2	2	2	2	2	2	2	2	2	2
2.	Clamping elbow fi22 x GZ3/4"	pc.	1	1	1	1	1	1	1	1	1	1	1	1
3.	Compensator fi22 x fi22	pc.	0	2	4	6	8	10	12	14	16	18		
4.	Cross fitting fi22 x GZ3/4" with a vent	pc.	1	1	1	1	1	1	1	1	1	1	1	1

### 3.1.11 The delivery completeness for clamp connecting system „on a pipe union” for meandric collector – vertical installation

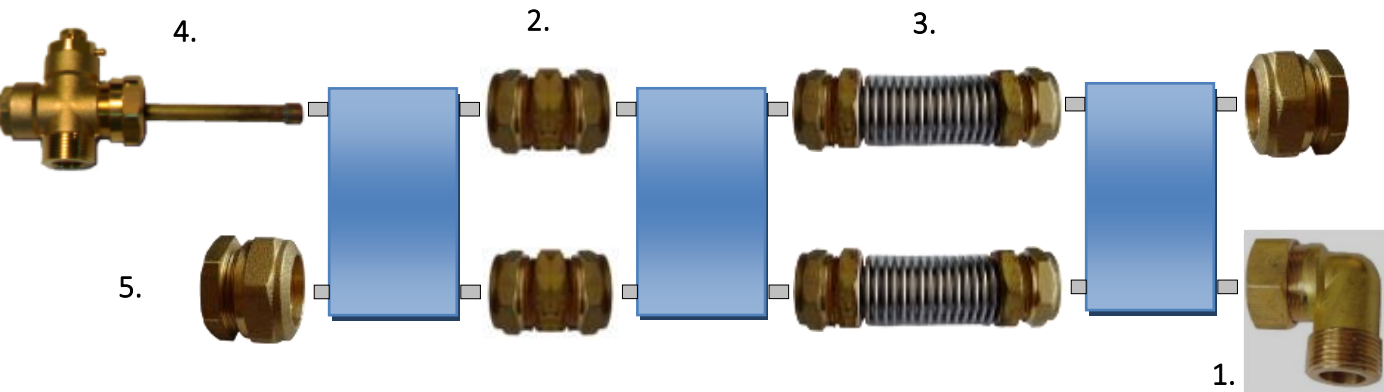

No.	Name	unit	Battery x				
			1	2	3	4	5
1.	Elbow fi22 x GZ3/4"	pc.	1	1	1	1	1
2.	Pipe union fi22 x fi22	pc.	0	2	4	4	6
3.	Compensator fi22 x fi22*	pc.	0	0	0	2	2
4.	Cross fitting fi22 x GZ3/4" with a vent	pc.	1	1	1	1	1
5.	Clamping end cap fi22	pc.	2	2	2	2	2

\*In case of a battery with 4 and 5 collectors, the compensator needs to be placed between 2nd and 3rd collector.

### 3.1.12 The delivery completeness for o-ring v.1 connecting system „on the compensator” for meandric collector – horizontal installation

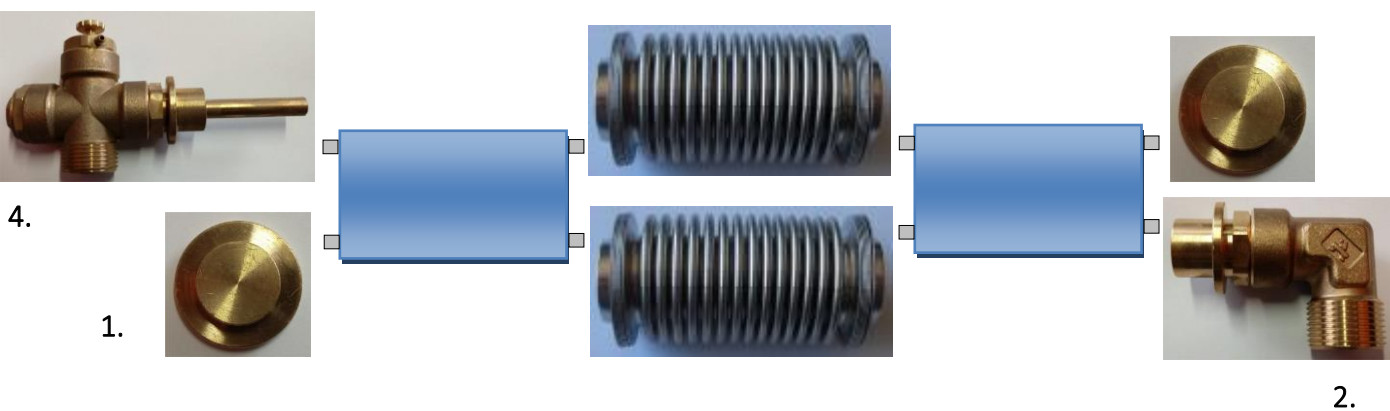

No.	Connecting system for meandric collectors Name	unit	Battery x				
			1	2	3	4	5
1.	End cap o-ring v.1	pc.	2	2	2	2	2
2.	Elbow o-ring v.1	pc.	1	1	1	1	1
3.	Compensator o-ring v.1	pc.	0	2	4	6	8
4.	Cross fitting with a vent o-ring v.1	pc.	1	1	1	1	1
5.	Gasket o-ring v.1	pc.	4	8	12	16	20
6.	Clasp o-ring v.1	pc.	4	8	12	16	20

### 3.1.13 The delivery completeness for o-ring v.1 connecting system „on the compensator” for meandric collector Al-Al – vertical installation

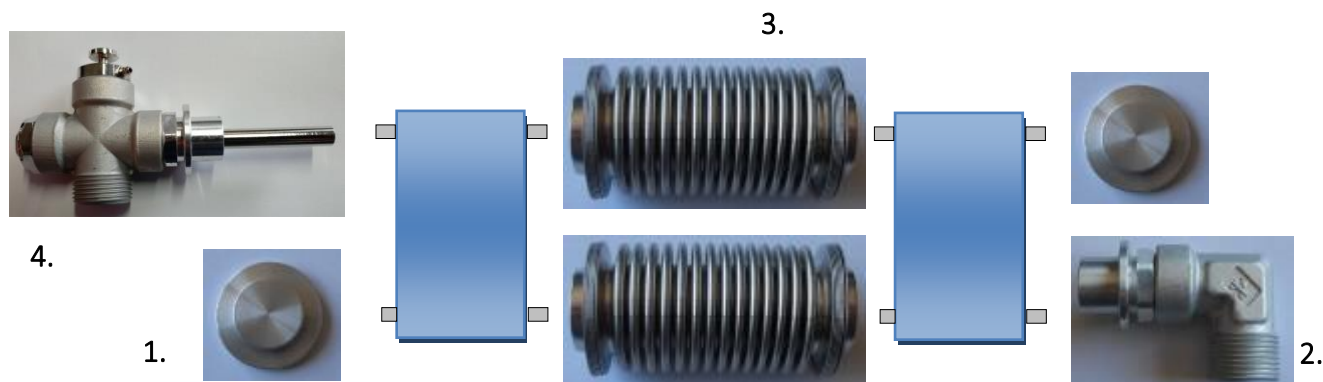

No.	Connecting system for meandric collectors Name	unit	Battery x				
			1	2	3	4	5
1.	End cap o-ring v.1	pc.	2	2	2	2	2
2.	Elbow o-ring v.1	pc.	1	1	1	1	1
3.	Compensator o-ring v.1	pc.	0	2	4	6	8
4.	Cross fitting with a vent o-ring v.1	pc.	1	1	1	1	1
5.	Gasket o-ring v.1	pc.	4	8	12	16	20
6.	Clasp o-ring v.1	pc.	4	8	12	16	20

### 3.1.14 The delivery completeness for o-ring v.1 connecting system „on the compensator” for hybrid collector – vertical installation

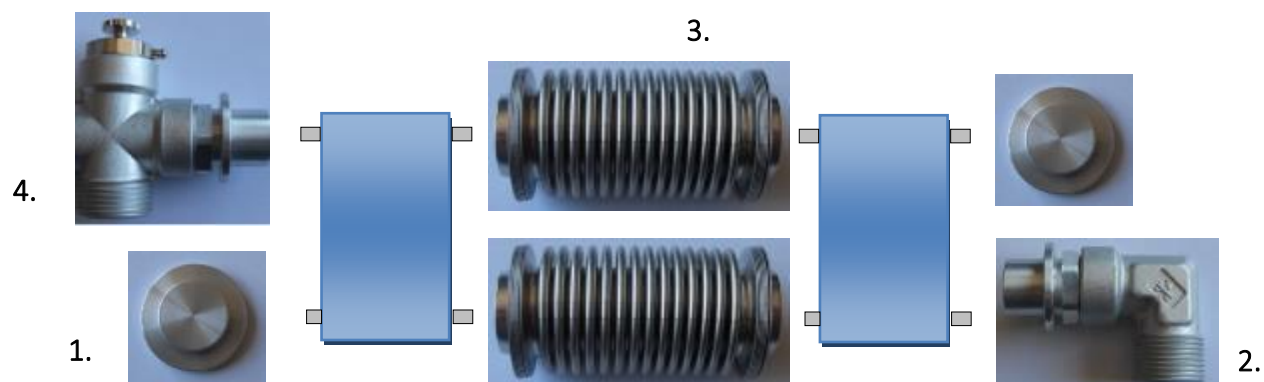



No.	Connecting system Name	unit	Battery x				
			1	2	3	4	5
1.	End cap o-ring v.1	pc.	2	2	2	2	2
2.	Elbow o-ring v.1	pc.	1	1	1	1	1
3.	Compensator o-ring v.1	pc.	0	2	4	6	8
4.	Tee connector with a o-ring v.1 vent	pc.	1	1	1	1	1
5.	Gasket o-ring v.1	pc.	4	8	12	16	20
6.	Clasp o-ring v.1	pc.	4	8	12	16	20

### 3.2 Shipment and storage



- during shipment the collector connectors are protected by rubber caps,
- the collectors should be stored in a dry place. If the collectors are stored outside they should be protected from atmospheric agents.

### 3.3 Technical documentation

Solar installation set consists of different components. Before installing any of them you should become familiar with an adequate instruction. Installation instructions are attached to a given device or piece of equipment.

- installation instruction for solar collectors,
- installation instruction for a pump group,
- installation instruction for a solar controller,
- installation instruction hot water tank.

### 3.4 Tools and additional equipment

- level gauge,
- harness with a safety cable (for work at heights),
- scaffolding, a roof ladder or a crane.

### 3.5 Collector location

Potential quantity of the absorber radiation depends on a proper location of the absorber in relations to incident rays. Collector surface horizontal position to radiation is an optimum manner.

Recommended location of a collector:

- inclination angle:
  - 40 – 45° for yearlong installations
  - approx. 30° for installations used during summer
  - approx. 60° for installations used during winter
- positioning of a collector in the southern direction (or approximate to the southern direction).

**Collectors recommended, optimal angle of inclination ranges from 30° to 75°.**

It is recommended to install collectors on a south-facing roofs. During installation, particular attention should be paid to protection of the collectors against strong winds.

**The admissible snow and wind load amount is max. 2,0 kN/m<sup>2</sup>.**

A collector field should be located in a manner that the absorber will not be shadowed by the

adjacent buildings, trees, etc.

In case of a larger number of collector fields it is important for the front row not to shadow the one in the back.

### 3.6 The warranty conditions of installation and use of collectors can be found in the warranty card of a particular collector.

### 3.7 Application of collectors in coastal areas.

For collectors that are installed up to 500LM from the coastline – lack of warranty for an absorber with a high-selective coat.

It is recommended to apply collectors with an absorber with an increased resistance to seawater e.g. Mirosol TS.

## 4. Supporting construction installation

### 4.1 Inclination angle of the collectors

#### 4.1.1 Roof or flat surface

In case of collector installation on a roof or a flat surface, the inclination angle of an installing system corresponds directly to the assumed inclination of collectors.

#### 4.1.2 Roof or surface of inclination angle up to 20°

In case of roofs inclined in the southern direction „A” the roof inclination should be deducted from the assumed collector inclination. In case of roofs inclined in the northern direction „B”, the roof inclination should be added to the assumed collector inclination.

The obtained value indicates the inclination angle of the set.

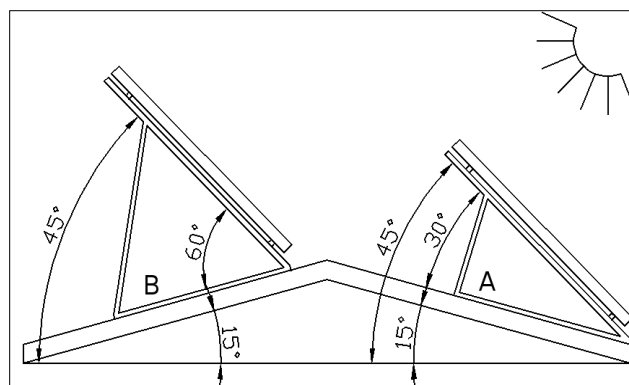

### 4.2 Setting the inclination angle

#### 4.2.1 Setting the inclination angle of an installation set for a horizontal collector

Inclination angle of an installation set can be adjusted by cutting the profile in a proper, marked spot. Standard angles of inclination were set at 30, 45 and 60°.

When it is necessary to set the installation set in a different angle one should make connection holes oneself, bearing in mind the maximum setting of the solar collector angle in the range of 15 - 60°.

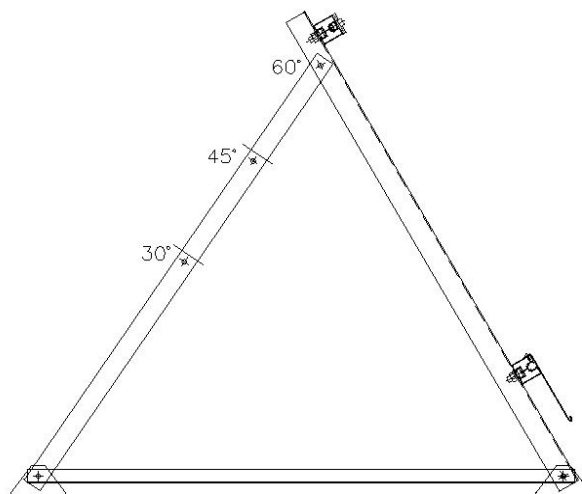

## 4.2.2 Setting the inclination angle of an installation set for a vertical collector

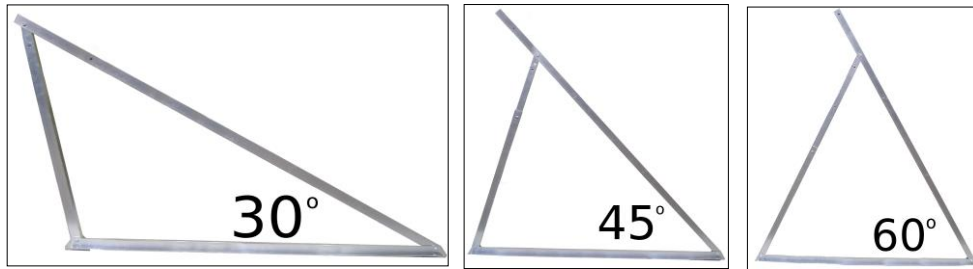

Inclination angle of an installation set can be adjusted by means of telescopic rails. Standard inclination angles have been determined as 30, 45 and 60° depending on the position of the installation set. In order to obtain the assumed inclination angle, it is necessary to connect properly the sections of the installation set.

30° angle is obtained by connecting the holes:  
A1 with B1 and B2 with C1.

45° angle is obtained by connecting the holes:  
A2 with B1 and B3 with C1.

60° angle is obtained by connecting the holes:  
A2 with B1 and B4 with C1.

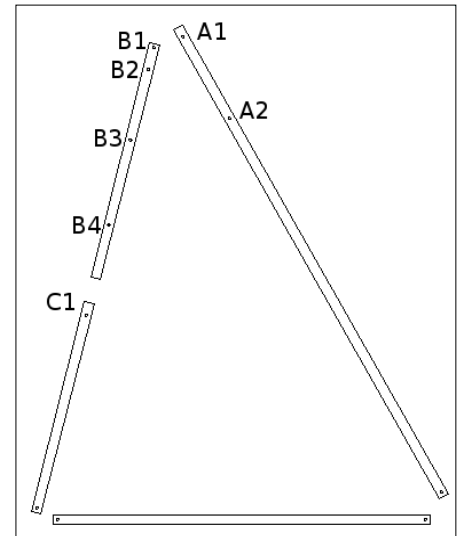

where:

A – Prop of supporting frame

B – Top strut

C – Bottom strut

In order to obtain the assumed angle of inclination in the mounting set V2, connect to the profile of the mounting set:

30 ° angle by trimming the struts of activities and activities A1 and B2 with C3.

45 ° angle is obtained by trimming the struts of activities and activities of B1 and B2 from C2.

60 ° angle is obtained by the activity of A2 from B1 and B2 from C1.

where:

A – Prop of supporting frame

B – Top strut

C – Bottom strut

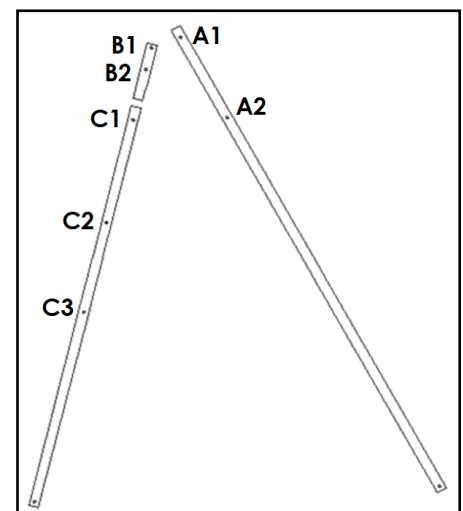

In order to obtain the assumed angle of inclination in the assembly set V3, connect the profiles of the assembly set appropriately:

The angle of  $30^\circ$  is obtained by cutting the strut and connecting the holes A1 with B3,

The angle of  $45^\circ$  is obtained by cutting the bottom and joining the holes A2 with B2,

The angle of  $60^\circ$  is obtained by connection of holes A2 with B1,

where:

A - Prop of supporting frame,

B - Strut.

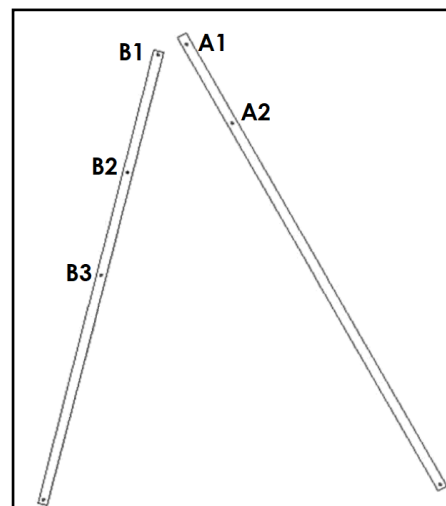

When it is necessary to position the installation set at a different angle, connection holes should be made by oneself, bearing in mind the maximum setting of the solar collector angle in the range of  $15^\circ - 75^\circ$ .

#### 4.2.3. Inclination angle for n installation set for flat collectors on an economical triangle (light version)

The construction allows setting the inclination angle only at  $45^\circ$ .

## 4.3 The installation set construction on a flat roof or a foundation for vertical collector

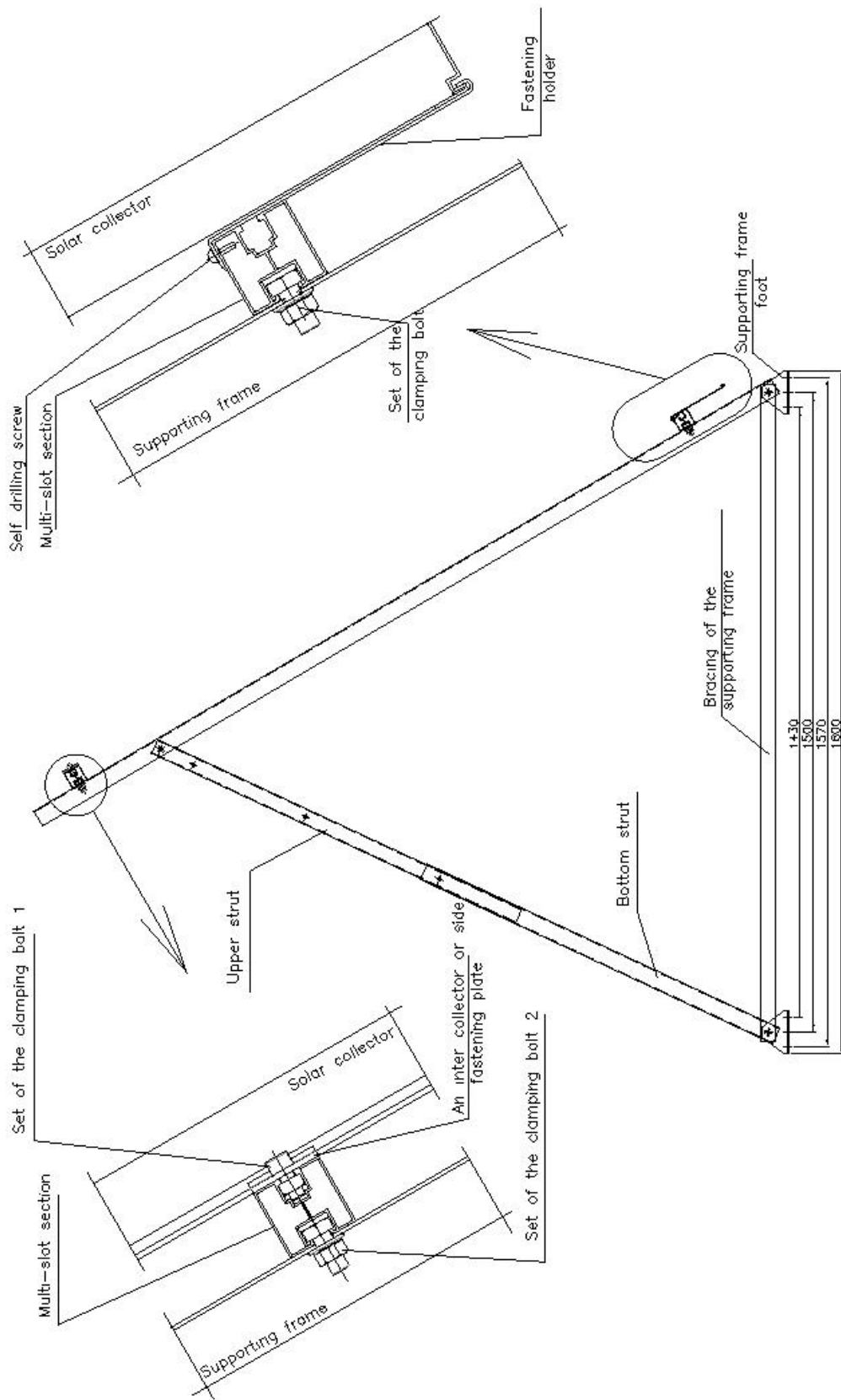

## 4.4 The assembly of supporting triangles

### 4.4.1 The assembly of supporting triangles for vertical collectors

The supporting triangles are the base of the installation set. All of the triangles are assembled in the same manner.

#### Note!

Before a supporting triangle assembly all of the components should be laid out according to the figure presented below.



When of all the components are arranged, the assembly triangle can be bolted together, bearing in mind the setting of a suitable inclination angle (4.2 Determining the inclination angle of the collectors).



## 4.4.2 The assembly of supporting triangles for a horizontal collector

The supporting triangles are the base of the installation set. All of the triangles are assembled in the same manner.

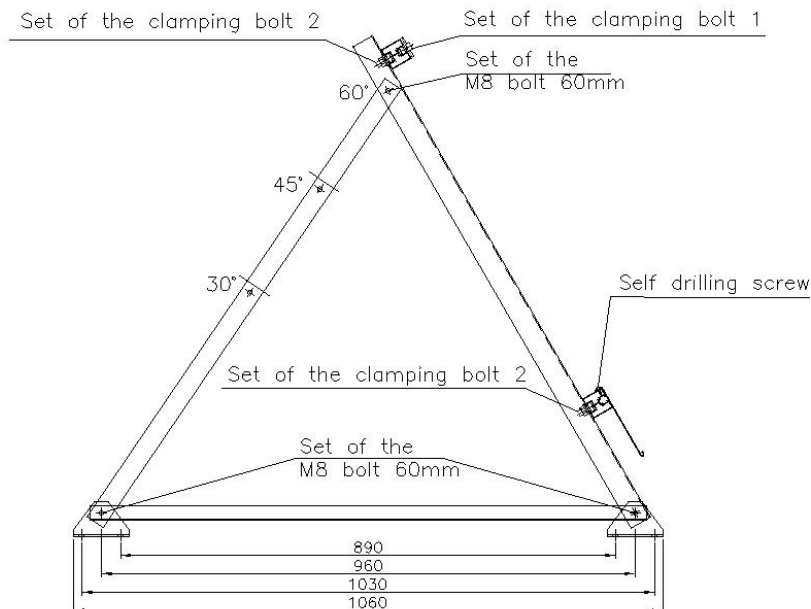

## 4.4.3 The assembly of supporting triangles and struts – light version (economical)

The supporting triangles are the base for an installation set. All of the triangles are assembled in the same manner. The installation distance between each triangle should be set accordingly with the dimensions shown in the figure.

The struts are bolted to the assembled triangles (ADDITIONAL OPTION).

### Note!

Before a supporting triangle assembly all of the components should be laid out according to the figure presented below.

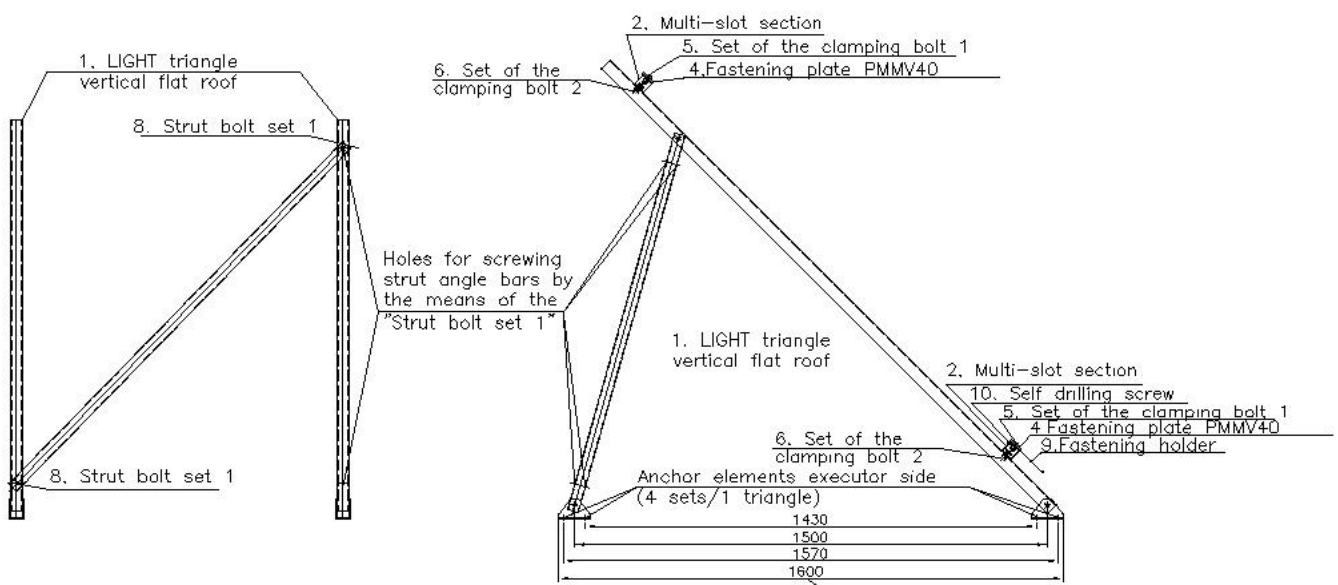

It is necessary to set the mounting distances between triangles feet according to the above dimensions

## 4.5 Determination of the minimal surface

Installation of the supporting constructions may take place only on a specially prepared surface. In case of collector installation on a flat roof the minimal distance between the collectors is 1m.

## 4.6 Number and spacing of the supporting triangles

Two supporting triangles are needed for the first collector. Each consecutive collector should be provided with one supporting triangle more.

Spacing between the supporting triangles depends on the quantity of the installed collectors and is respectively as follows:

Number of collectors	Triangle quantity	Triangle spacing [m]		
		Vertical collector 2,0m <sup>2</sup>	Vertical collector 2,52m <sup>2</sup> 2,65m <sup>2</sup>	Horizontal collector 2,65m <sup>2</sup>
1	2	0,806	0,920	1,956
2	3	0,956	1,070	2,233
3	4	1,006	1,120	2,325
4	5	1,031	1,145	2,371
5	6	1,046	1,160	2,399

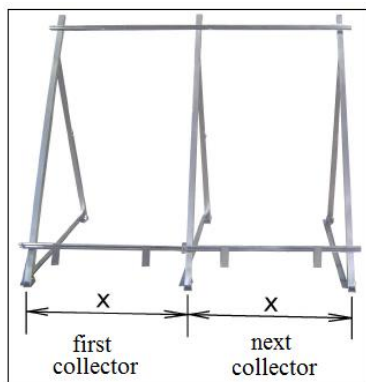

**Standard version**

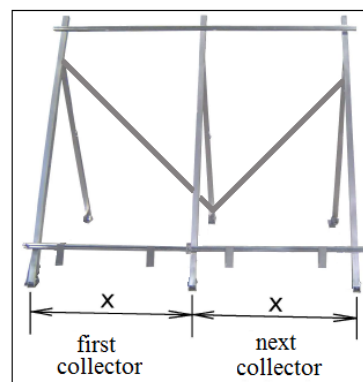

**Light version**

## 4.7 Number and configuration of multi-slot sections

The installation set includes an adequate number of multi-slot sections depending on the quantity of collectors in a set.

Assembly triangles are provided with holes for installing the multi-slot sections.



Tab. The section configurations and the number of multi-slot section connectors. The table below provides a joint number of sections and connectors for the sets of upper and bottom profiles.

Number of collectors	Vertical collector 2,0m <sup>2</sup>		Vertical collector 2,52m <sup>2</sup> Vertical collector 2,65m <sup>2</sup>		Horizontal collector 2,65m <sup>2</sup>
	Section 1120 mm	Section 22 2240mm	Section 1230 mm	Section 2460 mm	Section 2495 mm
1	2 pcs.	-	2 pcs.	-	2 pcs.
2	-	2 pcs.	-	2 pcs.	4 pcs.
3	2 pcs.	2 pcs.	2 pcs.	2 pcs.	6 pcs.
4	-	4 pcs.	-	4 pcs.	8 pcs.
5	2 pcs.	4 pcs.	2 pcs.	4 pcs.	10 pcs.

#### 4.8 Connecting the multi-slot sections

Multi-slot sections should be connected with each other in accordance with the table of configurations, according to the figure presented below:

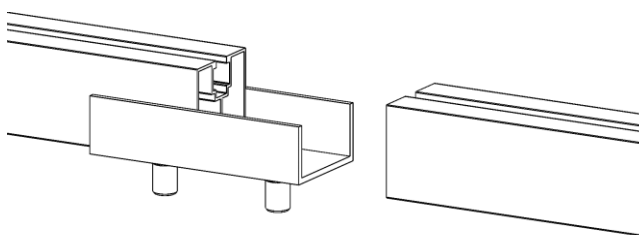

#### Note!

In order to avoid an uncontrolled displacement of a connector, screws M10x20 should be used

- set the connector at a distance of 50mm from the edge of the profile,
- using the supplied connecting element, profiles must be joined together.

#### 4.9 Connecting the multi-slot sections with the supporting triangles

The supplied bolts should be placed in the multi-slot sections in such quantity as supporting triangles according to the figure presented below.

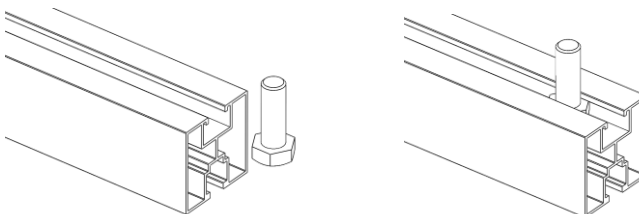

Taking into account spacing of the supporting triangles and the multi-slot sections, it is necessary to screw the multi-slot sections and the supporting triangles, according to the figure presented below.



## 4.10 Mounting a collector on a multi-slot section

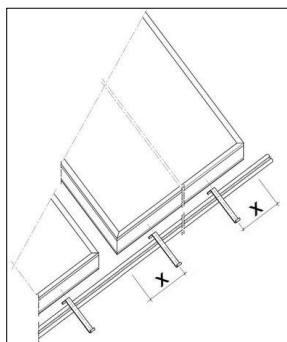

Each collector should rest on two fastening holders to prevent them from sliding down.

Fastening holders should be located at the distance of  $x = 200-250\text{mm}$  from the collector's edge.

## 4.11 Assembly of the fastening holders

The collector fastening holders should be assembled in the upper gap of the bottom multi-slot section, according to the figure presented below



**Fastening holder should be attached to the wider edge of the multi-slot section and counter it with a self-drilling screw.**

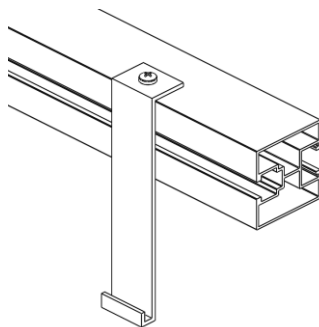

## 4.12 Fastening the structure to the surface

After assembly, the supporting structure should be put in its place of destination.

The supporting structure should be fixed to the surface with anchor bolts to prevent it from being torn out of the surface.

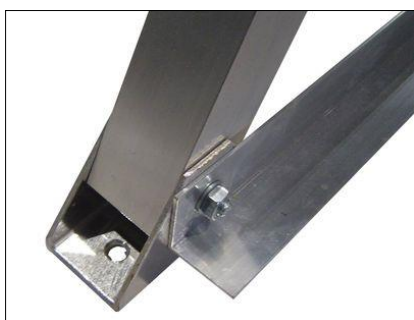

Via the holes in the foot of the supporting structure, the places where the structure should be attached must be marked.



After marking the holes:

- unbolt the foot of the supporting frame (the structure should be put gently away, so that it does not interfere with work),
- make the anchor holes,
- attach the base to the surface,
- bolt the foot to the supporting frame.

## 5. Collector installation



### Hazard

- when the work on the roof is carried out it is necessary to abide by safety rules in order to avoid accidents,
- when the work on the roof is carried out it is necessary to always protect oneself against falling down,
- installation should be carried out by at least two persons,
- protective clothing should be worn during work,
- upon completing the installation it must be checked if the installation set and the collectors have been installed in a stable manner.

### 5.1.1 Collector installation on a supporting structure for „on Compensator” set.

During a collector installation it is necessary to abide by all safety Note.

### Note!

During transport and installation the collectors need to have fall protection.

There are four fasteners for each collector, two per one section.

- Place the nuts in the sections, two per each collector,
- Place the collector on the multi-slot sections in such way that it is supported by the bottom fastening holders,
- Connect the collectors hydraulically with a compensator (see 5.4.1),
- Assemble the fastening plates by the bottom gap in the collector's frame, screw the bolt with the nut located in the section, according to the figure presented below.

Single fastening plates are provided at the edges and double ones between the collectors.

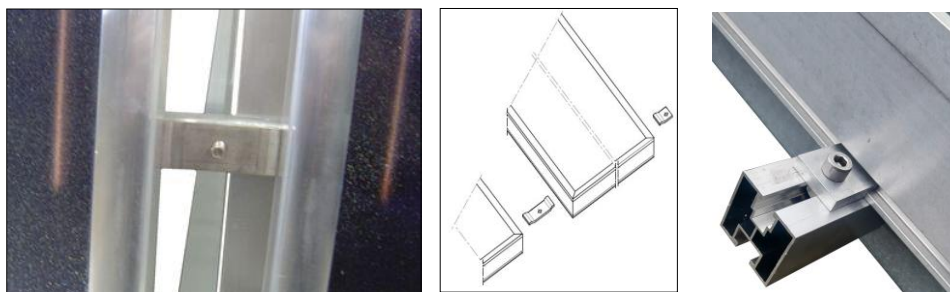

PMB35



PMM112

## 5.1.2 Collector installation on a supporting structure for „on a pipe union” set.

There are four fasteners, two per each section.

- Place the nuts in the sections, two per one section,
- Place the collector on the multi-slot sections in such way that it is supported by the bottom fastening holders,
- Connect the collectors hydraulically with a compensator (according to 5.4.1),
- Assemble the fastening plates to the bottom gap in the collector’s frame, screw the bolt with the nut located in the section, according to the figure presented below.

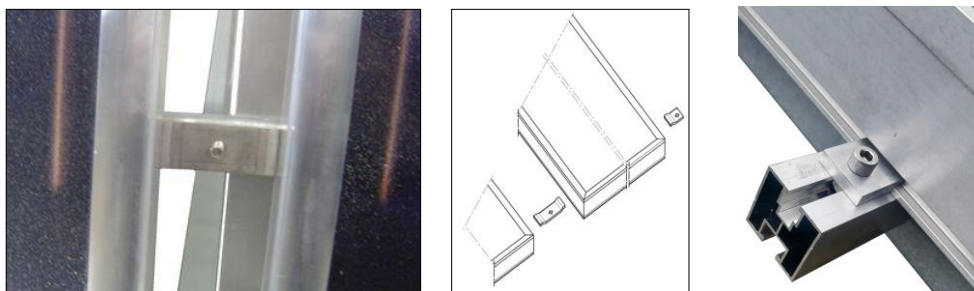

Single fastening plates are provided at the edges and double ones between the collectors.



PMB35



PMM112



PMM79

In the place of pipe union an inter-collector fastening plate PMM79 should be placed, it sets the distance between the collectors = 67mm. In the place of the compensator comes an inter-collector fastening plate PMM112, which sets the distance between the collectors = 100mm.

**In case of an installation of a battery of 4 or 5 collectors the compensator should be placed between 2<sup>nd</sup> and 3<sup>rd</sup> collector.**

## 6. A hydraulic connection of the collector

### ATTENTION!

**ALL CLAMPING CONNECTIONS ARE TO BE THIGHTENED WITH 45-50 Nm TORQUE CONTROL WHILE THIGHTING**

Counter wrench along with the connector cannot change its position during the screwing!

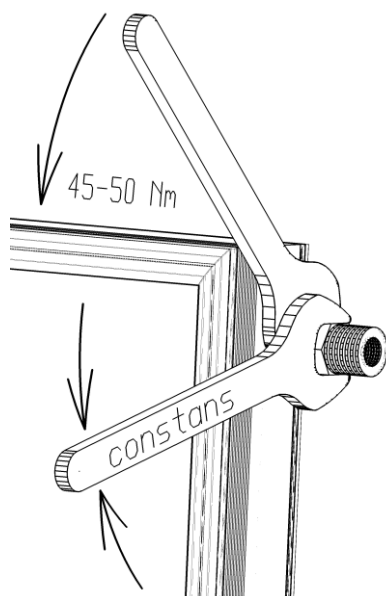

In case of a leak, tighten swivels of the connection sets with a torque of max. 80 Nm.

In case of further leaks, use a sealant Loxeal 8672 according to instructions on the sealants’ packaging.

## 6.1 Connection of double-harp collectors

### Note!

Hydraulic lines and fittings can be connected to the left or the right side of the collector battery. The instruction presents a right side connection as an example.

### Connection of max.5 collectors

Maximum 5 collectors may be connected to one battery. .

## 6.2 Connection of meander collectors

### Note!

The power supply<sup>\*1</sup> and return<sup>\*2</sup> must be connected diagonally of the collector or the battery, while the power supply<sup>\*1</sup> should be connected to the lower connector and the return<sup>\*2</sup> with a vent to the upper connector.

The connection of the power supply<sup>\*1</sup>/return<sup>\*2</sup> is arbitrary- it can be on the left or right side. The clamping plugs should be mounted in the two other connectors.

The instruction presents the power supply<sup>\*1</sup> on the right, and return<sup>\*2</sup> on the left side as an example.

### Connection of max.10 collectors

Maximum 10 collectors may be connected to one battery.

### 6.3.1 Collector connection with a clamping compensator

Double-harp collectors – connection of upper connectors

Meandric collectors – connection of lower and upper connectors

1. connection pipe,
2. strengthening sleeve,
3. compensator nut,
4. clamping ring,
5. compensator core.

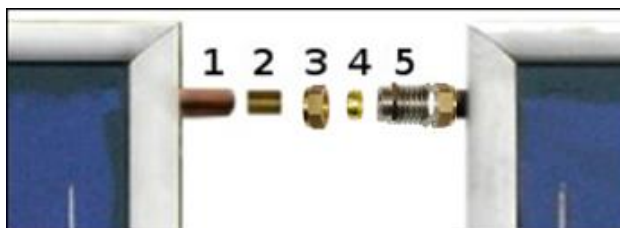

Place the compensator on the first collector's connector, then move the second collector closer and bolt the compensator on both collectors:

- the connection pipe (1) there is a pre-installed strengthening sleeve (2),
- place the compensator nut (3) on a connection pipe (1),
- place the clamping ring (4) on a connection pipe (1),
- screw the compensator nut (3) on a compensator,
- place the strengthening sleeve in the second collector's connection pipe,
- place the nut on a second collector's connection pipe,
- place the clamping ring on the second collector's connection pipe,
- move the second collector closer to the compensator,
- screw the nut on the compensator core.

### Note!

The nut should be tightened in a way that ensures tightness of the connection, however with a force that will not damage the collector's connection pipe.

\*<sup>1</sup> power supply = inlet of cold fluid \*<sup>2</sup> return = Outlet of warmed fluid

## 6.3.2 Connecting collectors' power supply \*1

1. connection pipe
2. strengthening sleeve
3. nut
4. clamping ring
5. elbow body
6. gasket
7. insulated flexible hose



- in the connection pipe (1) there is a pre-installed strengthening sleeve (2),
- place the elbow nut (3) on the connection pipe (1),
- place the clamping ring (4) on a connection pipe (1),
- screw the nut (3) on the elbow body (5),
- place the silicone gasket (6) in the insulated flexible hose nut (7),
- screw the flexible hose's nut (7) on the elbow body (5)
- connect the flexible hose to the solar system.

## 6.3.3 Connecting collectors' return \*2

1. connection pipe
2. strengthening sleeve
3. clamping nut
4. clamping ring
5. complete cross fitting with a manual vent and immersion sleeve
6. silicone gasket
7. insulated flexible hose

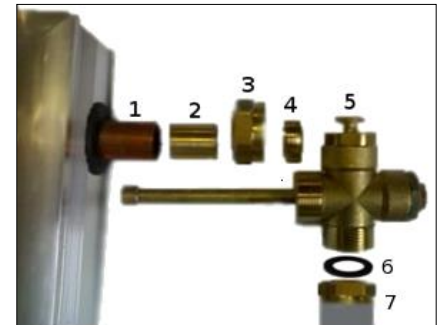

- in the connection pipe (1) there is a pre-installed strengthening sleeve (2),
- place the clamping nut (3) on the connection pipe (1),
- place the clamping ring (4) on the connection pipe (1),
- place the immersion sleeve with the complete cross fitting (5) on the connection pipe (1),
- screw the clamping nut (3) on the cross fitting (5) on the left side,
- place the silicone gasket (6) in the insulated flexible hose nut (7),
- screw the insulated flexible hose (7) on the cross fitting (5) from the bottom,
- connect the insulated flexible hose to the solar system.

## 6.3.4 Optional solution – mounting an automatic vent .

If necessary, you can mount an automatic vent with a valve and an adapter in the manual vent place instead.

- 7 – adapter  $\frac{3}{4}$  " x  $\frac{3}{8}$  "
- 8 – ball valve  $\frac{3}{8}$  "
- 9 – automatic vent  $\frac{3}{8}$  "



- unscrew from the top of the cross (5) fitting the manual vent
- to the top of the cross fitting (5) screw on successively, the adapter (7), the valve (8) and the automatic vent (9)

\*1 power supply = inlet of cold fluid \*2 return = Outlet of warmed fluid

**Note!**

Due to high temperatures in the solar system is necessary to use vents made completely out of metal.

**6.3.5 Connection of the clamping plugs – for meander collectors**

Mount the clamping plugs on the sub pipes that are not used for supply and return. (on the diagonal of the collector or the battery):

- 1 – clamping plug
- 2 – solar collector

- strengthening sleeve is pre-installed in the sub pipe,
- place the clamping nut on a connection pipe,
- place the clamping ring on a connection pipe,
- place the clamping plug on a connection pipe
- screw the clamping nut on a clamping plug.

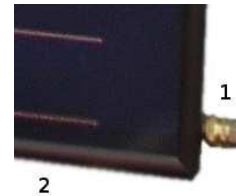

**6.4 Mounting an o-ring connecting system**

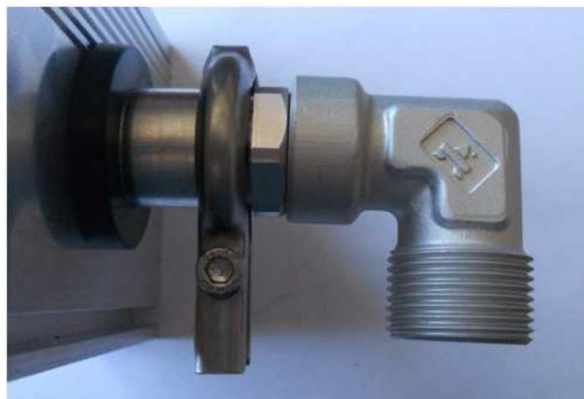

**6.4.1 Connecting elements mounting instruction**

- at the end of connecting elements one piece of o-ring (end cap, elbow, compensator) should be placed,
- a connecting system element with o-ring should be placed inside of a collecting pipe,
- then the clamp in the place of the collar should be put and tightened with an attached bolt.

## 6.5 Temperature sensor installation in clamping and o-ring connecting systems (except a hybrid collector).



### Installation damage

If the temperature sensor is incorrectly installed or the signal cable is damaged there is a danger of installation damage.

- it is necessary to protect the signal cable from damage (damage by birds, rodents) e.g. by using an electrical conduit.

The temperature sensor should be mounted in an immersion sleeve,

- insert the temperature sensor as far as possible into the immersion sleeve,

- secure the attached clamping spring from slipping.



## 6.6 Temperature sensor installation in a hybrid collector.



### Installation instruction for temperature sensor

- the sensor should be placed in a specially placed sleeve, mounted under a Ø22mm pipe (not in the transverse joint as in flat collectors),

- after placing the sensor in the sleeve (about 26cm) the sensor cable should be stabilized with a bolt.

## 6.7 Connection of collecting pipes

Hydraulic connection with collecting pipes should be executed by the means of insulated flexible cord. **Two rigid collecting pipes cannot be connected directly to a collector.**

The connection of flexible cords with the system should be done below the level of the vent.



### Note!

Use universal roof vents and aerial fittings to pass through the roof.



### Note!

Along with the flexible return cord run a temperature sensor cable.



## 7. Final works

### 7.1 Installation control

Upon the completion of the installation work it is necessary to:

- check the installation correctness of all elements of the system.
- carry out a pressure test of the system,
- flush the system,
- fill the system with the solar fluid.

After the pressure test and flushing the system it is necessary to immediately fill the system with the solar fluid. Otherwise, the tightness test and system flushing should be carried out directly before filling up the system with the solar fluid.

### 7.2 Filling up the system

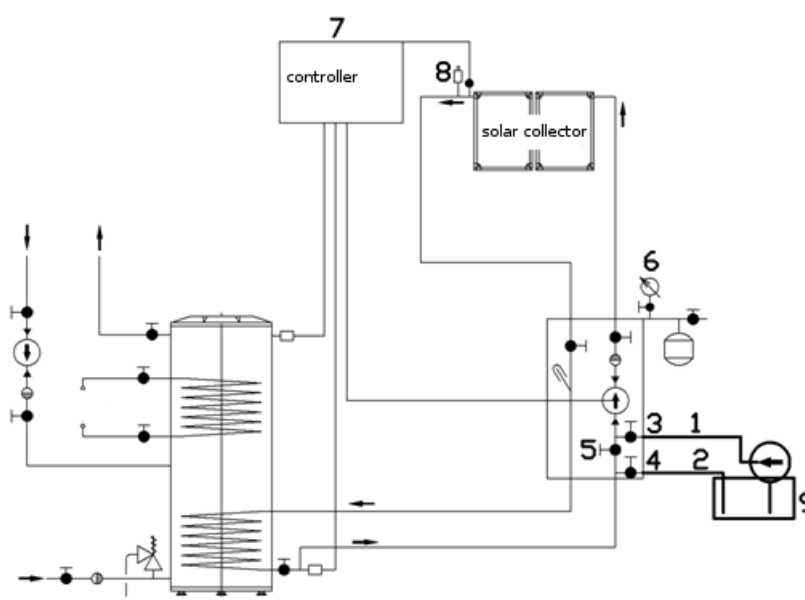

#### Filling up the system by using a filling station.

- Filling station hoses: (9): connect the pressure hose (1) with top drain valve (3), and transfer hose (2) with bottom drain valve (4).
- Fill the filling station tank with the heating fluid, open the drain valve (3 and 4) and start the pump.
- Close the ball valve (5) causing liquid flow through the solar collectors. During filling and venting the system, you should open and close the ball valve (5) several times.
- Do not turn off the pump until the system will be completely vented -that is, until the air bubbles cease to flow out of the transfer hose (2).
- Open the ball valve (5) and close the drain valve (4) continue to pump the heat medium to the system until the system will reach the required overpressure  $p = 2,5$  bar indicated by the manometer (6).
- Turn on the controller plug (7) to the network ~230V and turn on the circulation pump in the manual mode.
- The remnants of air should be removed automatically by opening the manual valve (8).
- In case of decrease or lack of flow (the flow regulator float – has dropped) one should unscrew the central screw in the circulation pump and release the air blocking the pump. Perform this action till the complete system is vented.
- In case of a pressure drop on a manometer (6) below 1,5 bar fill up to the required

overpressure in the system  $p = 2,5$  bar.

- Disconnect the filling station hoses from the drain valves (3 and 4).

### 7.3 Venting the solar system

After venting the system with the filling station and the manual vent it is necessary to close the vent valve, in case of an automatic vent it is necessary to close the ball valve.

### 7.4 Insulation work

Insulation work should be done after performing all control activities.

#### Note!

- To insulate the wires outside of a building, use insulation resistant to weather conditions and high temperature.

If necessary, protect the insulation against damage by birds.

- For insulation inside a building, use insulation resistant to high temperatures.

### 7.5 Masking profile installation – additional element \*.

Masking profile installation instruction.

Masking profile (1) is installed between collectors (2) by the means of three mounting elements (3).

By the means of mounting bolt (4) fix the mounting elements (3) to the masking profile (1). Placing the mounting elements: two pieces 20cm each from the masking profile's edge, third piece should be placed in inside the masking profile.

Mounting elements (3) should be clutched and successively placed in the top space between the collectors (2).

Press the masking profile (1) evenly along its entire length until the masking element's (3) latch snaps in the bottom pockets of collectors (2).

*\*A masking profile is not included in the basic set. It can be ordered as an additional option.*

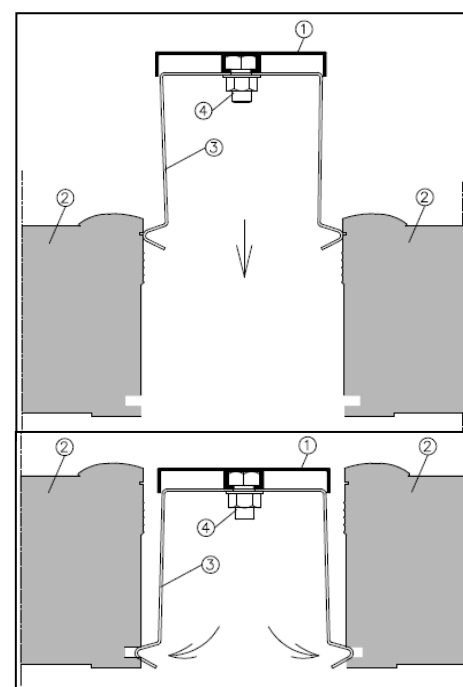
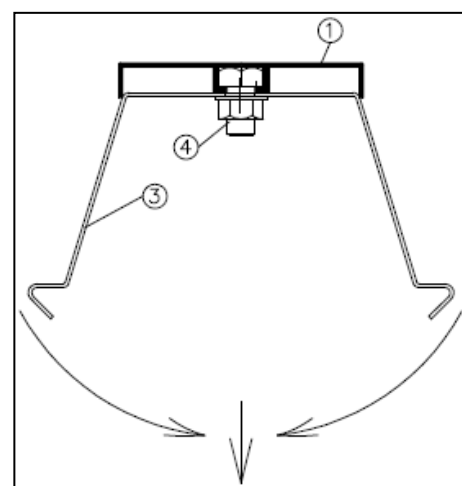

## 8. Maintenance and Service

During maintenance work and other work, the collector must be in a stable position to exclude the danger of tipping or falling.

- It is forbidden to carry out repairs and maintenance work under a raised or not protected against self-falling collector.
- Repair and maintenance work should be carried out by the means of suitable tools and protective gloves and shoes.
- Before g the maintenance work it is necessary to wait till the temperature of a collector lowers to such an extent that a burn hazard of fingers or hands is excluded,
- Solar system servicing should be carried out according to warranty indications of particular installation elements.

In order to guarantee failure-free operation of the whole system it is recommended to carry out the following maintenance works at least once a year:

- Frost protection – check the solar fluid resistance to frost by the means of a control device (refractometer). In case of a significant decrease of resistance of fluid against freezing it is necessary to replace it and vent the whole system once again.
- System pressure – working pressure in the solar system needs to be monitored. After the start-up period no pressure drop is allowed.
- Expansion vessel – input pressure of an expansion vessel should be monitored. In order to do so, disconnect the vessel from the system and measure the pressure. The input pressure should be 2,5 bar. It is also necessary to check the control and safety system and the supporting or fixing structure of the collectors.

**In order to guarantee the proper operation of the whole system in every case, it is recommended to sign a contract for maintenance services with specialized installation companies.**

**Copyright laws: Energetyka Solarna ensol Sp. z o.o.**

**Copying, replication and use of this work or its elements without authors' permission is strictly prohibited.**